

**KISTLER**

measure. analyze. innovate.



# Force Sensors

Transparent Manufacturing Processes  
Ensure Quality and Reduce Costs.



### **Kistler – Your Partner for Process Efficiency and Cost Effectiveness**

The Kistler Group is one of the world's leading manufacturers of sensors and systems to measure pressure, force, torque and acceleration. Kistler systems are used to analyze and evaluate measuring signals. The results of these evaluations help to improve process efficiency, ensuring a sustainable increase in companies' overall success.

# Content.

<b>Focus on Quality and Cost-Effectiveness</b>	4
<b>Product Overview: Force Sensors</b>	6
1-Component Force Sensors	7
Multi-component Force Sensors	26
Strain Sensors	34
Strain Gage Sensors	38
<b>Basics of Measurement Technology</b>	
Piezoelectric Measurement Technology	42
Measuring Methods	44
Strain Gage Measurement Technology	45
<b>Measuring Chains</b>	46
<b>Calibration</b>	48
<b>Service: Customized Solutions from A to Z</b>	50
<b>Kistler – At Our Customers' Service Across the Globe</b>	51



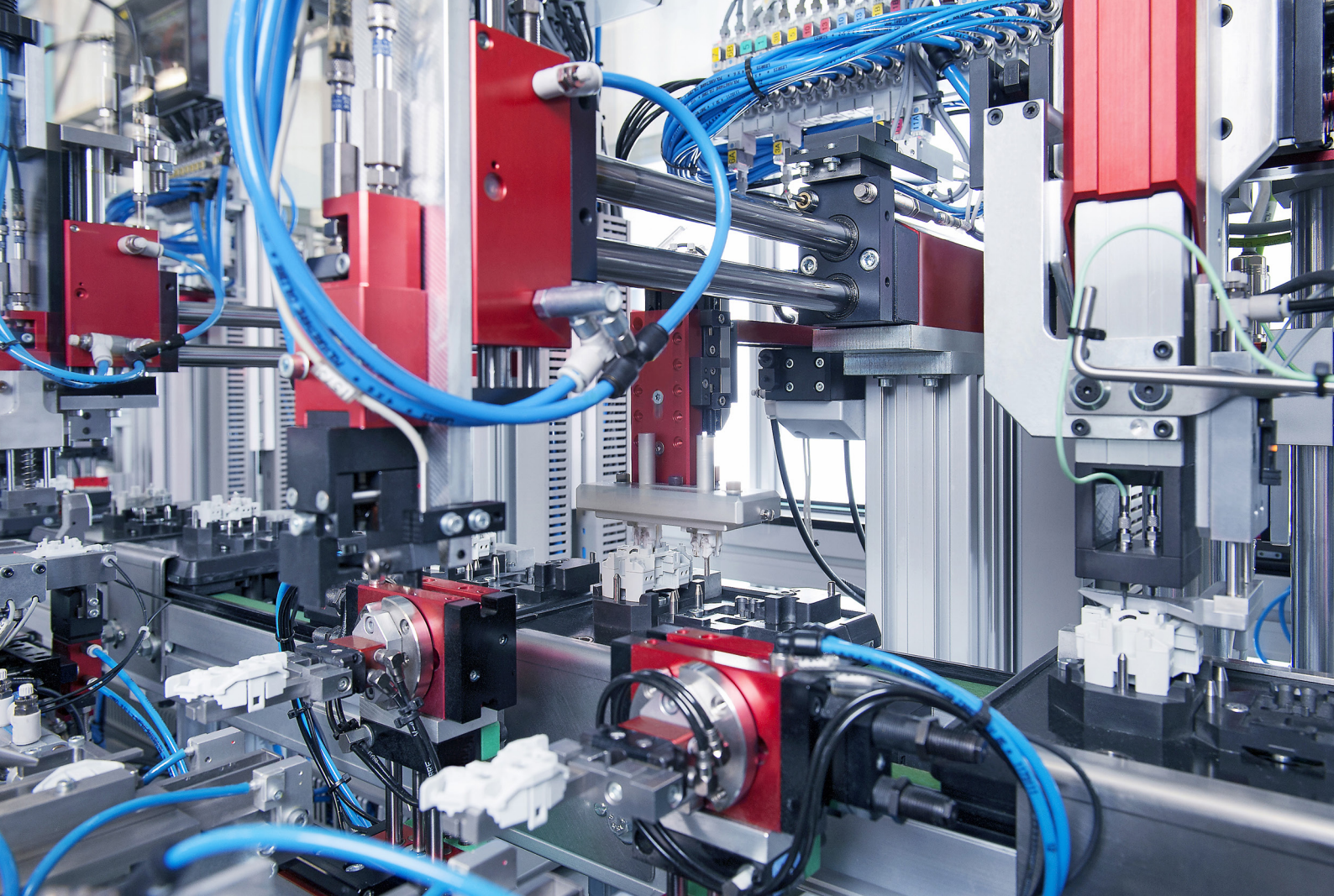

Assembly processes and product testing are just two of the many industrial activities where sensors from Kistler are used

# Focus on Quality and Cost-Effectiveness.

**Quality and precision standards in industrial manufacturing are continually increasing while competition is becoming even more fierce, thereby making it essential to optimize and monitor the entire production chain. Kistler's measurement and system technology can help meet these requirements, laying the foundations for zero-defect industrial production.**

Ensuring the quality of the end product is always the top priority in the automotive industry and the medical technology or electrical engineering sectors (to mention only a few examples); and this is why strict standards are specified for this purpose. Especially if many individual components are assembled to form one single product, each component must already have been tested by the suppliers: this is the only way to guarantee the quality of the end product. In many such cases, the only solution is to integrate monitoring systems into the production process.

- Force measurement is integrated in the production process
- Process monitoring ensures zero-defect production
- Quality costs are cut because deviations are detected at an early stage
- Process efficiency is optimized due to the flexibility of the measuring equipment



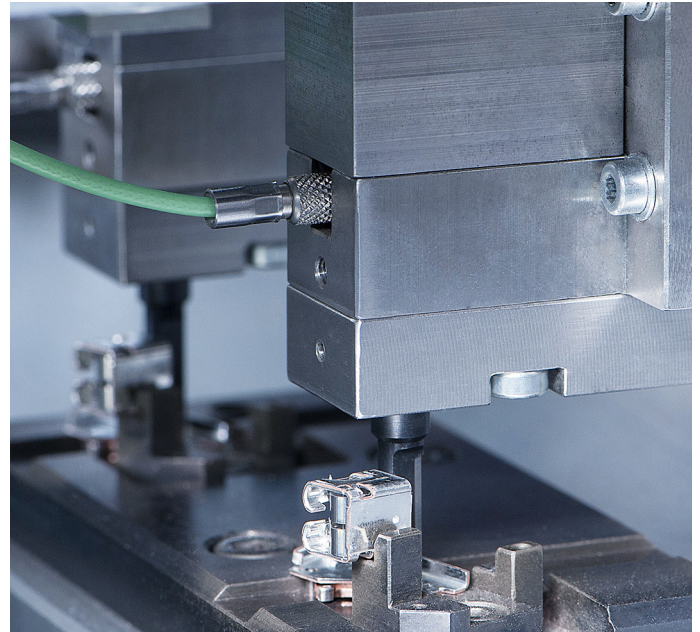
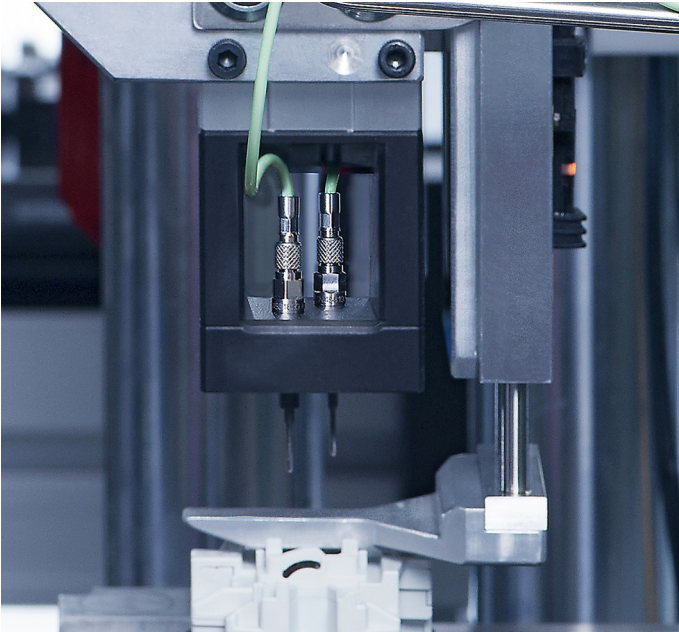

### **Optimized Process Efficiency Thanks to Technology from Kistler**

The objective: to implement zero-defect industrial production at the lowest possible cost. Kistler's response: integrated process monitoring, which means direct verification during each process step. This concept is underpinned by sensor technology based on the piezoelectric principle – an approach that is outstandingly suitable for monitoring and optimizing production processes.

### **Lower Quality Assurance Costs for Plant Operators**

Process-integrated monitoring cuts the costs of quality assurance. This cost-effective solution protects plant operators against the possibility of faulty parts reaching the customer; it also ensures that there is no disruption to any downstream assembly operations.



### **Increased Process Efficiency with Kistler – Now Online!**











View our animation to experience convincing, first-class Kistler solutions – the sure way to optimize process efficiency:



[www.kistler.com/maxymos](http://www.kistler.com/maxymos)



# Product Overview: Force Sensors

## Piezoelectric Sensors

Direct Force Measurement	Measurement Type	Preloaded	Ready for Measurement	N										Pages			
				-100000	-10000	-1000	-100	0	100	1000	10000	100000	1000000				
 Force Sensor	Fz	↕															8-9
 Force Link	Fz	↕	•	•													10-11
 Press Force	Fz	↕	•	•													12-13
 SlimLine	Fz	↕															14-17
 SlimLine Force Link	Fz	↕	•	•													18-19
 SlimLine Shear Force	Fy	↔															20-21
 Low Force	Fz	↕	•	•													22-23
 Miniature Sensor	Fz	↕		•													24-25
 3-Component Force Sensor	Fx, Fy, Fz	↕↔															28-29
 3-Component Force Link	Fx, Fy, Fz	↕↔	•	•													30-31
 Dynamometers	Fx, Fy, Fz, Mz	↕↔	•	•													32-33

Indirect Force Measurement	Measurement Type	Preloaded	Ready for Measurement	μ										Pages			
				-100000	-10000	-1000	-100	0	100	1000	10000	100000	1000000				
 Surface Strain Sensor	μ	↔		•													35
 Strain Measuring Pin	μ	↕		•													36-37

## Strain Gage Sensors

Direct Force Measurement	Measurement Type	Preloaded	Ready for Measurement	N										Pages			
				-100000	-10000	-1000	-100	0	100	1000	10000	100000	1000000				
 Strain Gage Force Sensors	Fz	↕		•													38-41



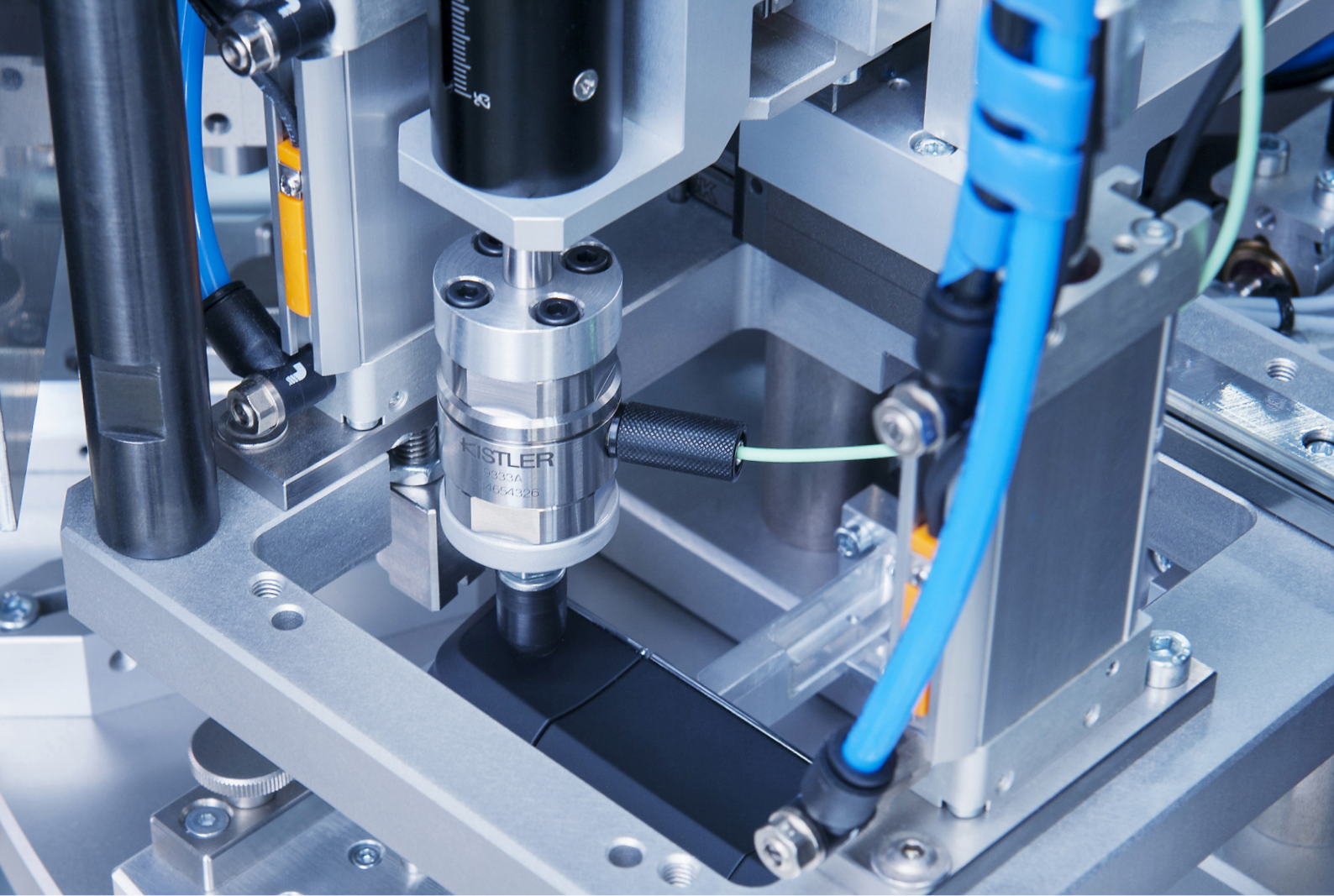

# 1-Component Force Sensors.

The force sensors in our portfolio utilize the outstanding properties of piezo crystals and quartzes, providing the basis for our sensor technology.

The load washer is the standard piezoelectric measuring element. The sensor elements themselves are only slightly preloaded. They are typically integrated into the existing structure at the measuring point, where they are installed with the required preload. This preload corresponds to a load offset.

Our force links and press force sensors can be used directly by customers for immediate measurements. These preloaded quartz force links are calibrated in the factory, and are suitable for measuring compression and tensile forces.





Our low level force sensors are designed for extremely small forces. Thanks to their internal structure, these sensors are up to 30 times more sensitive so that even the smallest forces can be measured reliably.

## Benefits

- Extremely rigid, so that high natural frequencies can be attained
- High loading capacity
- Durable
- Compact design
- Broad measuring range
- Direct measurements in the force flux
- Measurements without deflection are possible
- Extensive range

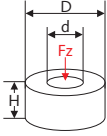

# 1-Component Force Sensors

Technical Data		Type	9001A	9011A	9021A	9031A	
							
Measuring range	Fz <sup>1)</sup>	kN	0 ... 7,5	0 ... 15	0 ... 35	0 ... 60	
Calibrated meas. ranges	Fz	kN	0 ... 6 <sup>2)</sup>	0 ... 12 <sup>2)</sup>	0 ... 28 <sup>2)</sup>	0 ... 48 <sup>2)</sup>	
	Fz	kN	0 ... 0,6 <sup>2)</sup>	0 ... 1,2 <sup>2)</sup>	0 ... 2,8 <sup>2)</sup>	0 ... 4,8 <sup>2)</sup>	
Sensitivity	Fz <sup>1)</sup>	pC/N	≈ -4,0	≈ -4,3	≈ -4,3	≈ -4,3	
Dimensions	D	mm	10,3	14,5	22,5	28,5	
	d	mm	4,1	6,5	10,5	13	
	H	mm	6,5	8	10	11	
Rigidity	c <sub>A,z</sub>	kN/μm	≈ 1,1	≈ 1,6	≈ 3,4	≈ 5,4	
Weight		g	3	7	20	36	
Operating temp. range <sup>3)</sup>		°C	-196 ... 200	-196 ... 200	-196 ... 200	-196 ... 200	
Connector			KIAG 10-32 neg.	KIAG 10-32 neg.	KIAG 10-32 neg.	KIAG 10-32 neg.	
Deg. of protection to IEC/EN 60529	screwed with cable (e.g. 1631C...)	IP65	•	•	•	•	
	welded with cable (e.g. 1983AD...)	IP67	•	•	•	•	

## Accessories

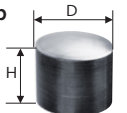
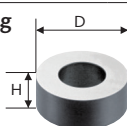
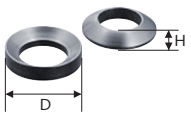





Preloading screw <sup>4)</sup> Thread × pitch/ length Preloading force		Type	9422A01	9422A11	9422A21	9422A31
		Fv (kN)	M3 × 0,5 / 19,5 2,5	M5 × 0,8 / 26 5	M8 × 1,25 / 39 10	M10 × 1,5 / 46 20
Preloading element Thread × pitch/ length Preloading force		Type	9420A01	9420A11	9420A21	9420A31
		Fv (kN)	M3 × 0,5 / 22 4	M5 × 0,5 / 28 7	M8 × 1 / 40 18	M10 × 1 / 46 30
Insulating washer Dimensions		Type		9517	9527	9537
		D (mm) S (mm)		14 0,125	22 0,125	28 0,125
Force distributing cap Dimensions		Type	9509	9519	9529	9539
		D (mm) H (mm)		10 10	14 15	22 20
Force distributing ring Dimensions		Type	9505	9515	9525	9535
		D (mm) H (mm)		10 6	14 8	22 10
Spherical washer Dimensions		Type		9513	9523	9533
		D (mm) H (mm)		12 4	21 6	24 7

<sup>1)</sup> without preloading

<sup>2)</sup> with a preload of 20% of the measuring range





<sup>3)</sup> operating temperature range depends on the cable used

<sup>4)</sup> included in delivery

9041A	9051A	9061A	9071A	9081B	9091B
					
0 ... 90	0 ... 120	0 ... 200	0 ... 400	0 ... 650	0 ... 1200
0 ... 72 <sup>2)</sup> 0 ... 7,2 <sup>2)</sup>	0 ... 96 <sup>2)</sup> 0 ... 9,6 <sup>2)</sup>	0 ... 160 <sup>2)</sup> 0 ... 16 <sup>2)</sup>	0 ... 320 <sup>2)</sup> 0 ... 32 <sup>2)</sup>	0 ... 650 0 ... 65	0 ... 1200 0 ... 120
≈ -4,3	≈ -4,3	≈ -4,3	≈ -4,3	≈ -2,2	≈ -2,2
34,5 17 12	40,5 21 13	52,5 26,5 15	75,5 40,5 17	100 40,5 22	145 72 28
≈ 6,9	≈ 9,8	≈ 15	≈ 29	30	65
70	80	157	370	910	2180
-196 ... 200	-196 ... 200	-196 ... 200	-196 ... 200	-40 ... 200	-40 ... 200
KIAG 10-32 neg.	KIAG 10-32 neg.	KIAG 10-32 neg.	KIAG 10-32 neg.	KIAG 10-32 neg.	KIAG 10-32 neg.
• •	• •	• •	• •	• •	• •

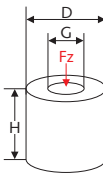
<b>9422A41</b> M12 × 1,75 / 53 30	<b>9422A51</b> M14 × 2 / 60 40				
<b>9420A41</b> M12 × 1 / 60 45	<b>9420A51</b> M14 × 1,5 / 62 60	<b>9420A61</b> M20 × 1,5 / 80 100	<b>9420A71</b> M27 × 2 / 102 200	<b>9455</b> M40 × 2 450	<b>9456</b> M64 × 3 600 (hydraulic)
<b>9547</b> 34 0,125	<b>9557</b> 40 0,125	<b>9567</b> 52 0,125	<b>9577</b> 75 0,125		
<b>9549</b> 34 30	<b>9559</b> 40 40	<b>9569</b> 52 50	<b>9579</b> 75 60		
<b>9545</b> 34 12	<b>9555</b> 40 13	<b>9565</b> 52 15	<b>9575</b> 75 17		
<b>9543</b> 30 8	<b>9553</b> 36 10	<b>9563</b> 52 14	<b>9573</b> 75 20		

# 1-Component Quartz Force Links redundant

Technical Data	Type	9301B	9311B	9321B	
					
Measuring range	Fz	kN	-2,5 ... 2,5	-5 ... 5	-10 ... 10
Calibrated meas. ranges	Fz	kN	0 ... 2,5	0 ... 5	0 ... 10
	Fz	kN	0 ... -2,5	0 ... -5	0 ... -10
	Fz	kN	0 ... 0,025	0 ... 0,05	0 ... 0,1
Sensitivity	Fz	pC/N	≈-3,2	≈-4	≈-4
Dimensions	D	mm	11	15	23
	H	mm	25	30	45
	G		M5	M6	M10
Rigidity	$c_{A,z}$	kN/μm	≈0,44	≈0,73	≈1,1
Natural frequency	$f_n(z)$	kHz	≈90	≈70	≈55
Weight		g	14	28	90
Operating temp. range <sup>1)</sup>		°C	-40 ... 120	-40 ... 120	-40 ... 120
Connector			KIAG 10-32 neg.	KIAG 10-32 neg.	KIAG 10-32 neg.
Deg. of protection to IEC/EN 60529	screwed with cable (e.g. 1631C...)	IP65	•	•	•
	welded with cable (e.g. 1983AD...)	IP67	•	•	•
With basic insulation			•	•	•
Preloaded			•	•	•
Ready for measurement			•	•	•
Datasheet: see <a href="http://www.kistler.com">www.kistler.com</a>			9301B (000-107)	9301B (000-107)	9301B (000-107)

## Accessories

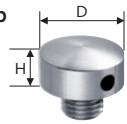
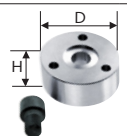
Force distributing cap Dimensions		Type	9500A0	9500A1	9500A2
		D (mm)	8,5	12,5	18
		H (mm)	4	6	9
Flange Dimensions		Type	9501A0	9501A1	9501A2
		D (mm)	25	34	44
		H (mm)	8	9	16

**Note:**  
These sensors are also available as reference sensors with excellent linearity (up to  $\pm \leq 0,1\%$  FSO) and SCS calibration, with type designation 93 × 1BK. They are especially well-suited for calibrations (e.g. as factory reference sensors).

<sup>1)</sup> operating temperature range depends on the cable used







<b>9331B</b>	<b>9341B</b>	<b>9351B</b>	<b>9361B</b>	<b>9371B</b>
--------------	--------------	--------------	--------------	--------------

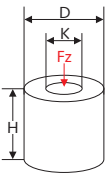

-20 ... 20	-30 ... 30	-40 ... 40	-60 ... 60	-120 ... 120
0 ... 20 0 ... -20 0 ... 0,2	0 ... 30 0 ... -30 0 ... 0,3	0 ... 40 0 ... -40 0 ... 0,4	0 ... 60 0 ... -60 0 ... 0,6	0 ... 120 0 ... -120 0 ... 1,2
≈ -4	≈ -4	≈ -4	≈ -4	≈ -4
29 52 M12	35 62 M16	41 72 M20	53 88 M24	76 108 M30
≈ 1,6	≈ 2,1	≈ 2,4	≈ 3,1	≈ 6,1
≈ 45	≈ 40	≈ 33	≈ 28	≈ 22
170	330	480	1020	2500
-40 ... 120	-40 ... 120	-40 ... 120	-40 ... 120	-40 ... 120
KIAG 10-32 neg.	KIAG 10-32 neg.	KIAG 10-32 neg.	KIAG 10-32 neg.	KIAG 10-32 neg.
•	•	•	•	•
•	•	•	•	•
•	•	•	•	•
•	•	•	•	•
<b>9301B (000-107)</b>	<b>9301B (000-107)</b>	<b>9301B (000-107)</b>	<b>9301B (000-107)</b>	<b>9301B (000-107)</b>

<b>9500A3</b> 23 12	<b>9500A4</b> 31 15	<b>9500A5</b> 35 18	<b>9500A6</b> 45 22	<b>9500A7</b> 64 32
<b>9501A3</b> 56 20	<b>9501A4</b> 70 27	<b>9501A5</b> 84 35	<b>9501A6</b> 102 42	<b>9501A7</b> 136 51





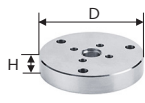
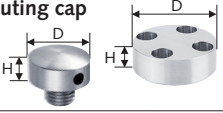
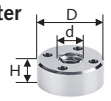
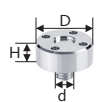

# 1-Component Quartz Force Links, Press Force

Technical Data		Type	9313AA1	9313AA2	9323AA	9323A
						
Measuring range	Fz	kN	0 ... 5	0 ... 20	0 ... 10	0 ... 20
Permissible tensile force	Fz	kN	0 ... -0,5	0 ... -2	0 ... -1	0 ... -2
Calibrated meas. ranges	Fz	kN	0 ... 0,05	0 ... 0,2	0 ... 0,1	0 ... 0,2
	Fz	kN	0 ... 0,5	0 ... 2	0 ... 1	0 ... 2
	Fz	kN	0 ... 5	0 ... 20	0 ...	0 ... 20
Sensitivity	Fz	pC/N	≈-10	≈-10	≈-9,6	≈-3,9
Output signal			V			
Dimensions	D	mm	13	19	20	20
	K	mm	M2,5	M4	M5×0,5	M5×0,5
	H	mm	10	14	26	26
Rigidity	$c_{A,z}$	kN/μm	≈0,56	≈1,50	≈1,30	≈1,20
Natural frequency	$f_n(z)$	kHz	>38	>35	>74,5	>72
Weight			10	25	50	47
Operating temp. range <sup>1)</sup>			-40 ... 120	-40 ... 120	-40 ... 120	-40 ... 120
Connector			KIAG 10-32 neg.	KIAG 10-32 neg.	KIAG 10-32 neg	KIAG 10-32 neg
Deg. of protection to IEC/EN 60529 screwed with cable (e.g. 1631C...) welded with cable (e.g. 1983AD...) screwed with cable (e.g. 1787A...)	IP65		•	•	•	•
	IP67		•	•	•	•
	IP67					
Preloaded			•	•	•	•
Ready for measurement			•	•	•	•
<b>Datasheet: see <a href="http://www.kistler.com">www.kistler.com</a></b>			<b>9313 (000-705)</b>	<b>9313 (000-705)</b>	<b>9323 (000-704)</b>	<b>9323 (000-704)</b>

## Accessories

Flange Dimensions		Type	<b>9580A7</b>	<b>9580A8</b>	<b>9580A9</b>	<b>9580A9</b>
		D (mm)	27	35	40	40
H (mm)	7	8	8	8	8	
Force distributing cap Dimensions		Type	<b>9500A00</b>	<b>9500A01</b>	<b>9582A9</b>	<b>9582A9</b>
		D (mm)	6	10,5	20	20
H (mm)	3	5	8,5	8,5	8,5	
Spigot Dimensions		Type	<b>9590A7</b>	<b>9590A8</b>		
		D (mm)	5	10		
L (mm)	12,5	20,5				
Female Thread Adapter Dimensions		Type			<b>9584A9</b>	<b>9584A9</b>
		D (mm)			20	20
H (mm)			8	8	8	
Male Thread Adapter Dimensions		Type			<b>9586A9</b>	<b>9586A9</b>
		D (mm)			20	20
H (mm)			8	8	8	



1) operating temperature range depends on the cable used

9333A	9343A	9363A	9383A	9393A	9337A40
					
0 ... 50	0 ... 70	0 ... 120	0 ... 300	0 ... 700	0 ... 70
0 ... -5	0 ... -10	0 ... -20	0 ... -50	0 ... -120	
0 ... 0,5 0 ... 5 0 ... 50	0 ... 0,7 0 ... 7 0 ... 70	0 ... 1,2 0 ... 12 0 ... 120	0 ... 3 0 ... 30 0 ... 300	0 ... 7 0 ... 70 0 ... 700	0 ... 5 0 ... 50
≈-3,9	≈-3,9	≈-3,8	≈-1,9	≈-1,9	
					0 ... 10
30 M9×0,5 34	36 M13×1 42	54 M20×1,5 60	100 S28×2 130	145 31 190	50 45
≈2,30	≈2,60	≈4,40	≈7,90	≈10,0	≈2,34
>55	>47	>35	>17	>11,3	>32
137	240	800	6490	18 663	520
-40 ... 120	-40 ... 120	-40 ... 120	-40 ... 120	-40 ... 120	-10 ... 70
KIAG 10-32 neg	KIAG 10-32 neg	KIAG 10-32 neg	KIAG 10-32 neg	KIAG 10-32 neg	M12×1 8-pole, shielded
• •	• •	• •	• •	• •	•
•	•	•	•	•	•
•	•	•	•	•	•
<b>9323 (000-704)</b>	<b>9323 (000-704)</b>	<b>9323 (000-704)</b>	<b>9323 (000-704)</b>	<b>9323 (000-704)</b>	<b>9337A (000-664)</b>

<b>9580A0</b> 62 11	<b>9580A1</b> 70 13	<b>9580A2</b> 100 22	<b>9580A4</b> 180 30	<b>9580A6</b> 220 48	<b>9594A1</b> 80 13
<b>9582A0</b> 30 11	<b>9582A1</b> 36,5 13	<b>9582A2</b> 56 22	<b>9582A4</b> 100 50	<b>9582A6</b> 145 80	<b>9582A1</b> 36,5 13
<b>9584A0</b> 30 11	<b>9584A1</b> 36,5 14	<b>9584A2</b> 56 21	<b>9584A4</b> 100 30	<b>9584A6</b> 150 48	<b>9584A1</b> 36,5 14
<b>9586A0</b> 30 11	<b>9586A1</b> 36,5 14	<b>9586A2</b> 56 21	<b>9586A4</b> 100 30	<b>9586A6</b> 150 48	<b>9586A1</b> 36,5 14

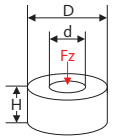

# 1-Component Force Sensors





Technical Data	Type	9101A	9102A
			
Measuring range	$F_z^{1)}$	kN	0 ... 20
Calibrated meas. ranges	not calibrated		
Sensitivity	$F_z^{1)}$	pC/N	$\approx -4,3$
Dimensions	D	mm	14,5
	d	mm	6,5
	H	mm	8
Rigidity	$c_{A,z}$	kN/ $\mu$ m	$\approx 1,6$
Weight		g	7
Operating temp. range <sup>2)</sup>		$^{\circ}$ C	-40 ... 120
Connector			KIAG 10-32 neg.
Deg. of protection to IEC/EN 60529			
screwed with cable (e.g. 1631C...)		IP65	•
welded with cable (e.g. 1983AD...)		IP67	•
Datasheet: see <a href="http://www.kistler.com">www.kistler.com</a>			9101A (000-108)

## Accessories

<b>Preloading screw</b> Thread x pitch/length Preloading force		<b>Type</b>  Fv (kN)	<b>9422A11</b> M5 x 0,8 / 26 5	<b>9422A21</b> M8 x 1,25 / 39 10
<b>Preloading element</b> Thread x pitch/length Preloading force		<b>Type</b>  Fv (kN)	<b>9420A11</b> M5 x 0,5 / 28 7	<b>9420A21</b> M8 x 1 / 40 18
<b>Insulating washer</b> Dimensions		<b>Type</b> D (mm) S (mm)	<b>9517</b> 14 0,125	<b>9527</b> 22 0,125
<b>Force distributing cap</b> Dimensions		<b>Type</b> D (mm) H (mm)	<b>9519</b> 14 15	<b>9529</b> 22 20
<b>Force distributing ring</b> Dimensions		<b>Type</b> D (mm) H (mm)	<b>9515</b> 14 8	<b>9525</b> 22 10
<b>Spherical washer</b> Dimensions		<b>Type</b> D (mm) H (mm) (total)	<b>9513</b> 12 4	<b>9523</b> 21 6





<sup>1)</sup> without preloading

<sup>2)</sup> operating temperature range depends on the cable used

9103A	9104A	9105A	9106A	9107A
				
0 ... 100	0 ... 140	0 ... 190	0 ... 330	0 ... 700
≈ -4,3	≈ -4,3	≈ -4,3	≈ -4,3	≈ -4,3
28,5 13 11	34,5 17 12	40,5 21 13	52,5 26,5 15	75,5 40,5 17
≈ 5,4	≈ 6,9	≈ 9,8	≈ 15	≈ 29
36	70	80	157	370
-40 ... 120	-40 ... 120	-40 ... 120	-40 ... 120	-40 ... 120
KIAG 10-32 neg.	KIAG 10-32 neg.	KIAG 10-32 neg.	KIAG 10-32 neg.	KIAG 10-32 neg.
• •	• •	• •	• •	• •
9101A (000-108)	9101A (000-108)	9101A (000-108)	9101A (000-108)	9101A (000-108)

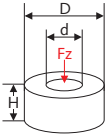
9422A31 M10 × 1,5 / 46 20	9422A41 M12 × 1,75 / 53 30	9422A51 M14 × 2 / 60 40		
9420A31 M10 × 1 / 46 30	9420A41 M12 × 1 / 60 45	9420A51 M14 × 1,5 / 62 60	9420A61 M20 × 1,5 / 80 100	9420A71 M27 × 2 / 102 200
9537 28 0,125	9547 34 0,125	9557 40 0,125	9567 52 0,125	9577 75 0,125
9539 28 25	9549 34 30	9559 40 40	9569 52 50	9579 75 60
9535 28 11	9545 34 12	9555 40 13	9565 52 15	9575 75 17
9533 24 7	9543 30 8	9553 36 10	9563 52 14	9573 75 20

# 1-Component Force Sensors, SlimLine

Technical Data		Type	9130B...	9131B...	9132B...	
						
Measuring range	$F_z^{1)}$	kN	0 ... 3	0 ... 2,5	0 ... 7	
Calibrated meas. ranges	not calibrated					
Sensitivity	$F_z^{1)}$	pC/N	$\approx -3,5$	$\approx -4$	$\approx -3,8$	
Dimensions	D	mm	8	7	12	
	d	mm	2,7	-	4,1	
	H	mm	3	3	3	
Rigidity	$c_{A,z}$	kN/ $\mu$ m	$\approx 1$	$\approx 0,9$	$\approx 2,1$	
Weight (without cable)			1	1	2	
Operating temperature range			$-20 \dots 120$	$-20 \dots 120$	$-20 \dots 120$	
Connector (with integrated cable)			optional: KIAG 10–32 pos. int. or Mini-Coax neg.	optional: KIAG 10–32 pos. int. or Mini-Coax neg.	optional: KIAG 10–32 pos. int. or Mini-Coax neg.	
Deg. of protection to IEC/EN 60529	IP65		•	•	•	
<b>Datasheet: see <a href="http://www.kistler.com">www.kistler.com</a></b>			<b>9130B (000-110)</b>	<b>9130B (000-110)</b>	<b>9130B (000-110)</b>	

## Accessories

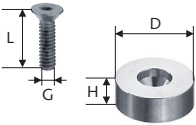
Preloading disk		Type	9410A0	9410A2
Dimensions		G	M2	M2,5
		L (mm)	8	8
		D (mm)	8	12
		H (mm)	3,5	3,5

<sup>1)</sup> without preloading

# 1-Component Force Sensor Assembly Kits Comprising 2, 3 or 4 Sensors

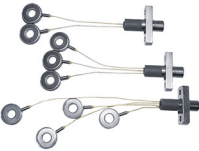
Technical Data		Type	9130BA...	9132BA...
				
Assembly kit comprises	Type	9130B		9132B
Connector (sensors are connected undetachably to the flange bushing)			Fischer flange 7-pole, neg.	Fischer flange 7-pole, neg.
Deg. of protection to IEC/EN 60529 with connected cable (e.g. 1971A...)	IP65	•		•
<b>Datasheet: see <a href="http://www.kistler.com">www.kistler.com</a></b>			<b>9130BA (000-694)</b>	<b>9130BA (000-694)</b>

<b>9133B...</b>	<b>9134B...</b>	<b>9135B...</b>	<b>9136B...</b>	<b>9137B...</b>
-----------------	-----------------	-----------------	-----------------	-----------------





0 ... 14	0 ... 26	0 ... 36	0 ... 62	0 ... 80
≈-3,8	≈-3,8	≈-3,8	≈-3,8	≈-3,8
16 6,1 3,5	20 8,1 3,5	24 10,1 3,5	30 12,1 4	36 14,1 5
≈3	≈6,3	≈7,8	≈12,8	≈18,8
3	5	7	14	27
-20 ... 120	-20 ... 120	-20 ... 120	-20 ... 120	-20 ... 120
optional: KIAG 10-32 pos. int. or Mini-Coax neg.	optional: KIAG 10-32 pos. int. or Mini-Coax neg.	optional: KIAG 10-32 pos. int. or Mini-Coax neg.	optional: KIAG 10-32 pos. int. or Mini-Coax neg.	optional: KIAG 10-32 pos. int. or Mini-Coax neg.
•	•	•	•	•
<b>9130B (000-110)</b>	<b>9130B (000-110)</b>	<b>9130B (000-110)</b>	<b>9130B (000-110)</b>	<b>9130B (000-110)</b>

<b>9410A3</b> M3 10 16 4,25	<b>9410A4</b> M4 10 20 4,25	<b>9410A5</b> M5 10 24 4,25	<b>9410A6</b> M6 14 30 5,5	<b>9410A7</b> M8 16 36 7
---	---	---	--	--------------------------------------

<b>9133BA...</b>	<b>9134BA...</b>	<b>9135BA...</b>	<b>9136BA...</b>	<b>9137BA...</b>
------------------	------------------	------------------	------------------	------------------

9133B Fischer flange 7-pole, neg.	9134B Fischer flange 7-pole, neg.	9135B Fischer flange 7-pole, neg.	9136B Fischer flange 7-pole, neg.	9137B Fischer flange 7-pole, neg.
•	•	•	•	•
<b>9130BA (000-694)</b>	<b>9130BA (000-694)</b>	<b>9130BA (000-694)</b>	<b>9130BA (000-694)</b>	<b>9130BA (000-694)</b>

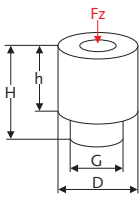
# 1-Component Quartz Force Links, SlimLine Force Link

Technical Data		Type	9173B	9174B
				
Measuring range	Fz	kN	-3 ... 12	-5 ... 20
Calibrated meas. range	Fz	kN	0 ... 12	0 ... 20
Sensitivity	Fz	pC/N	≈ -3,5	≈ -3,5
Dimensions	D	mm	18	22
	H	mm	22	24
	h	mm	14	16
	G		M12×1,25	M16×1,5
Rigidity	$c_{A,z}$	kN/μm	≈ 0,7	≈ 1,2
Natural frequency	$f_n(z)$	kHz	≈ 74	≈ 66
Weight (without cable)		g	28	40
Operating temperature range		°C	-20 ... 80	-20 ... 80
Connector <sup>1)</sup> (with integrated cable)			KIAG 10-32 neg.	KIAG 10-32 neg.
Deg. of protection to IEC/EN 60529	IP65		•	•
With basic insulation			•	•
Preloaded			•	•
Ready for measurement			•	•
Datasheet: see <a href="http://www.kistler.com">www.kistler.com</a>			9173B (000-112)	9173B (000-112)

## Accessories

Force distributing cap		Type	9416A3	9416A4
Dimensions	D (mm)		14	18
	H (mm)		6	8

<sup>1)</sup> plug coupling Type 1729A2 (included in delivery scope) fitted



**9175B**

-8 ... 30

0 ... 30

≈-3,5

26

28

19

M20×1,5

≈1,6

≈57

81

-20 ... 80

KIAG 10-32 neg.

•

•

•

•

**9173B (000-112)****9176B**

-16 ... 60

0 ... 60

≈-3,5

32

34

23

M24×2

≈2,4

≈47

147

-20 ... 80

KIAG 10-32 neg.

•

•

•

•

**9173B (000-112)****9177B**

-20 ... 75

0 ... 75

≈-3,5

38

38

28

M30×2

≈3,4

≈40

227

-20 ... 80

KIAG 10-32 neg.

•

•

•

•

**9173B (000-112)****9416A5**

22

9

**9416A6**

28



9

**9416A7**

34

9,8

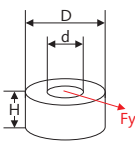
# 1-Component Force Sensors, SlimLine for Shear Force

Technical Data	Type	9143B...	9144B...	
				
Measuring range	F <sub>y</sub>	kN	-0,9 ... 0,9	-1,7 ... 1,7
Calibrated meas. ranges	not calibrated			
Sensitivity	F <sub>y</sub>	pC/N	≈ -6,5	≈ -7,5
Dimensions	D	mm	16	20
	d	mm	6,1	8,1
	H	mm	3,5	3,5
Rigidity (Z-axis)	c <sub>Az</sub>	kN/μm	≈ 3	≈ 6,3
Rigidity (Y-axis)	c <sub>sy</sub>	kN/μm	≈ 1,2	≈ 2,4
Weight (without cable)	g		3	5
Operating temperature range	°C		-20 ... 120	-20 ... 120
Connector (with integrated cable)			optional: KIAG 10–32 pos. int. or Mini-Coax neg.	optional: KIAG 10–32 pos. int. or Mini-Coax neg.
Deg. of protection to IEC/EN 60529	IP65		•	•
Datasheet: see <a href="http://www.kistler.com">www.kistler.com</a>			9143B (000-113)	9143B (000-113)

## Accessories

Preloading disk		Type	9410A3	9410A4
Dimensions		G	M3	M4
Tightening torque		L (mm)	10	10
		D (mm)	16	20
		H (mm)	4,25	4,25
		M (N·m)	10	23

# 1-Component Force Sensor Assembly Kits for Shear Force Comprising 2, 3 or 4 Sensors

Technical Data	Type	9143BA...	9144BA...
			
Assembly kit comprises	Type	9143B	9144B
Connector (nondetachable sensors are connected to the flange bushing)		Fischer flange 7-pole, neg.	Fischer flange 7-pole, neg.
Deg. of protection to IEC/EN 60529 with connected cable (e.g. 1971A...)	IP65	•	•
Datasheet: see <a href="http://www.kistler.com">www.kistler.com</a>		9143BA (000-766)	9143BA (000-766)

<b>9145B...</b>	<b>9146B...</b>	<b>9147B...</b>
-----------------	-----------------	-----------------





-2,7 ... 2,7	-4 ... 4	-8 ... 8
≈-7,5	≈-7,5	≈-8,1
24 10,1 3,5	30 12,1 4	36 14,1 5
≈ 7,8	≈ 12,8	≈18,8
≈ 3,1	≈ 5,1	≈ 7,1
7	14	27
-20 ... 120	-20 ... 120	-20 ... 120
optional: KIAG 10-32 pos. int. or Mini-Coax neg.	optional: KIAG 10-32 pos. int. or Mini-Coax neg.	optional: KIAG 10-32 pos. int. or Mini-Coax neg.
•	•	•
<b>9143B (000-113)</b>	<b>9143B (000-113)</b>	<b>9143B (000-113)</b>

<b>9410A5</b> M5 10 24 4,25 46	<b>9410A6</b> M6 14 30 5,5 79	<b>9410A7</b> M8 16 36 7 135
---	--	---

<b>9145BA...</b>	<b>9146BA...</b>	<b>9147BA...</b>
------------------	------------------	------------------

9145B Fischer flange 7-pole, neg.	9146B Fischer flange 7-pole, neg.	9147B Fischer flange 7-pole, neg.
•	•	•
<b>9143BA (000-766)</b>	<b>9143BA (000-766)</b>	<b>9143BA (000-766)</b>

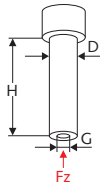
# 1-Component Quartz Force Link, Low Force

Technical Data		Type	9203	9205
  				
Measuring range	Fz	N	-500 ... 500	-50 ... 50
Calibrated meas. ranges	Fz	N	0 ... 5	0 ... -0,5 / 0 ... 0,5
	Fz	N	0 ... -50 / 0 ... 50	0 ... -5 / 0 ... 5
	Fz	N	0 ... -500 / 0 ... 500	0 ... -50 / 0 ... 50
Sensitivity	Fz	pC/N	≈ -45	≈ -115
Dimensions	D		M10×1	M10×1
	H	mm	28,5	28,5
	G		M3 (female thread)	M3 (female thread)
Rigidity	$c_{A,z}$	N/μm	≈ 40	≈ 4
Natural frequency	$f_n(z)$	kHz	> 27	> 10
Weight		g	13	19
Operating temp. range <sup>1)</sup>		°C	-150 ... 240	-50 ... 150
Connector			KIAG 10-32 neg.	KIAG 10-32 neg., radial
Deg. of protection to IEC/EN 60529 screwed with cable (e.g. 1631C...)	IP65		•	•
	welded with cable (e.g. 1983AD...)	IP67	•	•
Preloaded			•	•
Ready for measurement			•	•
Datasheet: see <a href="http://www.kistler.com">www.kistler.com</a>			9203 (000-127)	9205 (000-129)

## Accessories

Coupling element		Type	9405	9405
Dimensions	D (mm)		6,3	6,3
	H (mm)		18	18
Force introducing cap		Type	3.220.139	3.220.139 <sup>2)</sup>
Dimensions	D (mm)		6,3	6,3
	H (mm)		7	7

<sup>1)</sup> operating temperature range depends on the cable used

<sup>2)</sup> included in delivery

<b>9207</b>	<b>9215A</b>	<b>9217A</b>
-------------	--------------	--------------





-50 ... 50	-20 ... 200	-500 ... 500
0 ... -0,5 / 0 ... 0,5 0 ... -5 / 0 ... 5 0 ... -50 / 0 ... 50	0 ... 2 0 ... 20 0 ... 200	0 ... 5 0 ... -50 / 0 ... 50 0 ... -500 / 0 ... 500
≈ -115	≈ -95	≈ -105
M10×1 28,5 M3 (female thread)	M5×0,5 12,5 M2 (female thread)	M10×1 28,5 M3 (female thread)
≈4	≈100	≈15
>10	>50	>20
19	2,5	16
-50 ... 150	-50 ... 180	-80 ... 205
KIAG 10-32 neg., axial	M4×0,35 neg.	KIAG 10-32 neg.
•	•	•
•	•	•
•	•	•
•	•	•
<b>9207 (000-130)</b>	<b>9215 (000-487)</b>	<b>9217A (000-546)</b>

<b>9405</b> 6,3 18		<b>9405</b> 6,3 18
<b>3.220.139<sup>2)</sup></b> 6,3 7	<b>3.220.217<sup>2)</sup></b> 4 3,8	<b>3.220.139</b> 6,3 7

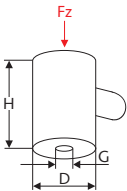

# 1-Component Quartz Force Link, Miniature

Technical Data		Type	9210	9211B
			 	
Measuring range	Fz	kN	0 ... 0,25	0 ... 2,5
Calibrated meas. ranges	Fz	kN	0 ... 0,25	0 ... 0,25
	Fz	kN	0 ... 0,25	0 ... 2,5
Rigidity	$c_{A,z}$	kN/ $\mu$ m	0,4	0,4
Natural frequency	$f_n(z)$	kHz	>200	$\approx$ 200
Sensitivity	Fz	pC/N	$\approx$ -10	$\approx$ -4,4
Dimensions	D	mm	3,5	6
	H	mm	4,7	6
	G			
Weight		g	1	1,5
Operating temp. range <sup>1)</sup>		$^{\circ}$ C	-40 ... 200	-40 ... 200
Connector			Fischer 102 Triax	Fischer 102 Triax
Cable technology				
Single wire with/without plug			•	•
Coaxial				•
Replaceable cable				•
Deg. of protection to IEC/EN 60529	IP65		•	•
Preloaded				
Ready for measurement			•	•
Datasheet: see <a href="http://www.kistler.com">www.kistler.com</a>			9210 (000-601)	9211 (000-555)

## Accessories

Thrust washer <sup>2)</sup>		Type	9406	9411
Dimensions	D (mm)		3,4	5,5
	H (mm)		2	2

<sup>1)</sup> operating temperature range depends on the cable used

<sup>2)</sup> included in delivery

9213B



0 ... 2,5

0 ... 0,25

0 ... 2,5

0,26

≈200

≈-4,4

6

8,5

M2,5 (female thread)

2

-40 ... 200

Fischer 102 Triax

- 
- 
- 

- 

- 

9213 (000-132)

9204



0 ... 10

0 ... 1,0

0 ... 10

0,16

≈80

≈-1,6

12,6

9,5

M2,5 (female thread)

8

-40 ... 200

Fischer 102 Triax

- 
- 
- 

- 

- 

9204 (000-128)

9212



-2,2 ... 22,2

0 ... 2,2

0 ... 22,2

0,87

≈70

≈-11

17,8

12,7

10-32 UNF

19

-196 ... 150

10-32 UNF

- 
- 

- 

- 

9212 (000-418)

9413  
5,5/2,8  
2

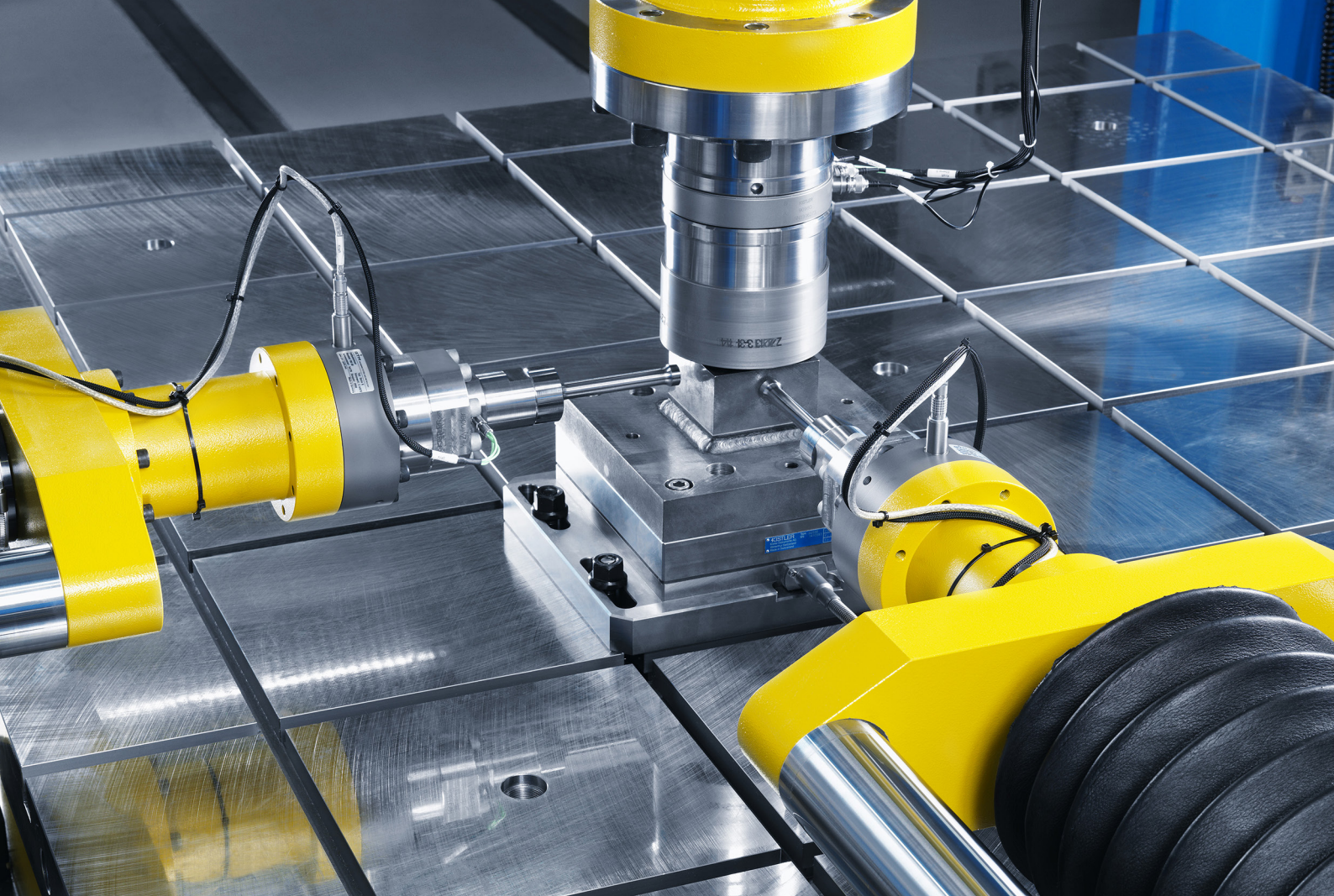

# Multi-component Force Sensors.

Kistler's piezoelectric sensors with multiple measuring directions are the elite class of piezoelectric force measuring instruments. These highly sensitive measuring elements are compactly embedded in the case, which is made of selected high-grade steel.



Multi-component load washers are the basic elements of the measurement technology. The sensor elements themselves are only slightly preloaded; they are integrated into the customer's structure and installed with the required preload. This preload corresponds to a load offset. Our Force Links can be used directly by customers for immediate measurements. These preloaded quartz Force Links are calibrated in the factory. They can be used in both directions along all measuring axes.

Multi-component force sensors are generally installed in groups of four, in what are known as dynamometers or measurement platforms. Single signals from the piezoelectric sensors can be summed by grouping the individual connectors together. This makes it possible to set up dynamometers that cover the range from 3-component force measurements to 6-component force/moment measurements. For this purpose, Kistler offers prepared sensor kits, as well as ready-to-use dynamometers.

## Benefits

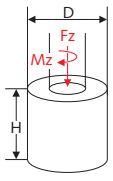

- Multi-component measurement
- Extremely rigid, so high natural frequencies can be attained
- Durable
- High loading capacity
- Compact design

## 2-Component Sensors, Miniature



Technical Data		Type	9345B	9365B
				
Measuring range	Fz Mz	kN N·m	-10 ... 10 -25 ... 25	-20 ... 20 -200 ... 200
Calibrated meas. ranges	Fz Mz	kN N·m	0 ... 1 0 ... 10 0 ... -2,5 / 0 ... 2,5 0 ... -25 / 0 ... 25	0 ... 2 0 ... 20 0 ... -20 / 0 ... 20 0 ... -200 / 0 ... 200
Rigidity (calculated)	$c_{A,z}$ $c_{T,z}$	kN/μm N·m/μm	≈1,7 ≈0,19	≈2,8 ≈0,92
Natural frequency	$f_n(z)$ $f_n(Mz)$	kHz kHz	>41 >32	>33 >25
Sensitivity	Fz Mz	pC/N pC/N·m	≈-3,7 ≈-190	≈-3,6 ≈-140
Dimensions	D H	mm mm	39 42	56.5 60
Weight		g	267	834
Operating temperature range		°C	-40 ... 120	-40 ... 120
Connector			V3 neg.	V3 neg.
Deg. of protection to IEC/EN 60529 screwed with cable (e.g. 1698AD...)		IP65	•	•
Preloaded			•	•
Ready for measurement			•	•
<b>Datasheet: see <a href="http://www.kistler.com">www.kistler.com</a></b>			<b>9345B (000-630)</b>	<b>9345B (000-630)</b>

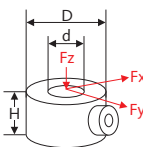

### 3-Component Force Sensors

Technical Data		Type	9017C/9018C	9027C/9028C
				
Measuring ranges	Fx, Fy Fz	kN kN	-1,5 ... 1,5 -3 ... 3 Standard installation with 9,5 kN preloading	-4 ... 4 -8 ... 8 Standard installation with 20 kN preloading
Calibrated meas. ranges	Fx, Fy Fz Fz (without preloading)	kN kN kN	0 ... 1,5 0 ... 3 0 ... 12,5	0 ... 4 0 ... 8 0 ... 28
Sensitivity	Fx, Fy Fz	pC/N pC/N	≈ -25 ≈ -11	≈ -7,8 ≈ -3,8
Dimensions	D d H	mm mm mm	19 6,5 10	28 8,1 12
Rigidity	$C_{s,xy}$ $C_{A,z}$	kN/μm kN/μm	0,3 1,4	0,6 2,2
Weight		g	14	30
Operating temperature range		°C	-40 ... 120	-40 ... 120
Connector			V3 neg.	V3 neg.
Deg. of protection to IEC/EN 60529				
screwed with cable (e.g. 1698AA/AB)	IP65		•	•
welded with cable (e.g. 1698ACsp)	IP67		•	•
<b>Datasheet: see <a href="http://www.kistler.com">www.kistler.com</a></b>			<b>9017C (000-960)</b>	<b>9027C (000-726)</b>

#### Accessories

<b>Preloading element</b> Thread x pitch/length Preloading force		<b>Type</b>	<b>9460</b> M6 x 0,75 / 29 9,5	<b>9461</b> M8 x 1 / 40 20
<b>Wrench adapter</b>		<b>Type</b>	<b>9479</b>	<b>9475</b>
<b>Preloading element</b> Thread x pitch/length Preloading force		<b>Type</b>		
<b>Wrench adapter</b>		<b>Type</b>		
<b>Preloading element</b> Thread x pitch/length Preloading force		<b>Type</b>		
<b>Wrench adapter</b>		<b>Type</b>		

**9047C/9048C**



-15 ... 15  
-30 ... 30  
Standard installation with 70 kN preloading

0 ... 15  
0 ... 30  
0 ... 100

≈ -8,1  
≈ -3,7

45  
14,1  
14

1,9  
6,1

91

-40 ... 120

V3 neg.

- 
- 

**9047C (000-592)**

**9067C/9068C**



-30 ... 30  
-60 ... 60  
Standard installation with 140 kN preloading

0 ... 30  
0 ... 60  
0 ... 200

≈ -8,1  
≈ -3,9

65  
26,5  
21

2,4  
8

285

-40 ... 120

V3 neg.

- 
- 

**9067C (000-609)**

**9077C/9078C**



-75 ... 75  
-150 ... 150  
Standard installation with 350 kN preloading

0 ... 75  
0 ... 150  
0 ... 500

≈ -4,2  
≈ -2

105  
40,5  
26

8,4  
26

1040

-40 ... 120

V3 neg.

- 
- 

**9077C (000-610)**

**9465**  
M14×1,5/57  
70

**9472**

**9451A**  
M20×1,5/78  
140

**9471**



**9455**  
M40×2/105  
350

**9473**

**9459**  
M26×0,75/76  
140

**9477**

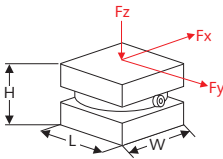
### 3-Component Quartz Force Links

Technical Data		Type	9317C	9327C
				
Measuring ranges	Fx, Fy Fz	kN kN	-0,5 ... 0,5 -3 ... 3	-1 ... 1 -8 ... 8
Calibrated meas. ranges	Fx, Fy Fz	kN kN	0 ... 0,05 / 0 ... 0,5 0 ... 0,3 / 0 ... 3	0 ... 0,1 / 0 ... 1 0 ... 0,8 / 0 ... 8
Sensitivity	Fx, Fy Fz	pC/N pC/N	≈ -25 ≈ -11	≈ -7,8 ≈ -3,8
Dimensions	L×W×H	mm	25×25×30	42×42×42
Rigidity	$c_{s,xy}$ <sup>1)</sup>	kN/μm	0,19	0,39
	$c_{A,z}$	kN/μm	0,9	1,4
Natural frequency	$f_n(x), f_n(y)$	kHz	≈ 5,6	≈ 3,2
	$f_n(z)$	kHz	≈ 20	≈ 12
Weight		g	85	380
Operating temperature range		°C	-40 ... 120	-40 ... 120
Connector			V3 neg.	V3 neg.
Deg. of protection to IEC/EN 60529	screwed with cable (e.g. 1698AA/AB)	IP65	•	•
	welded with cable (e.g. 1698ACsp)	IP67	•	•
With basic insulation			•	•
Preloaded			•	•
Ready for measurement			•	•
Datasheet: see <a href="http://www.kistler.com">www.kistler.com</a>			9317C (003-124)	9327C (000-725)

<sup>1)</sup> disregarding bending

9347C



-5 ... 5 -30 ... 30
0 ... 0,5 / 0 ... 5 0 ... 3 / 0 ... 30
≈ -7,8 ≈ -3,7
55×55×60
0,89 2,7
≈ 3,6 ≈ 10
1000
-40 ... 120
V3 neg.
•
•
•
•
•
9347C (000-604)

9367C



-10 ... 10 -60 ... 60
0 ... 1 / 0 ... 10 0 ... 6 / 0 ... 60
≈ -7,6 ≈ -3,9
80×80×90
1,2 3,8
≈ 2,4 ≈ 6
3000
-40 ... 120
V3 neg.
•
•
•
•
•
9367C (000-613)

9377C





-30 ... 30 -150 ... 150
0 ... 3 / 0 ... 30 0 ... 15 / 0 ... 150
≈ -3,9 ≈ -1,95
120×120×125
3,2 8,2
≈ 2 ≈ 6
10500
-40 ... 120
V3 neg.
•
•
•
•
•
9377C (000-612)

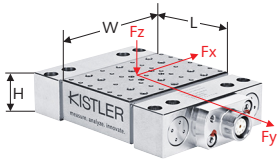
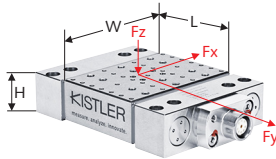
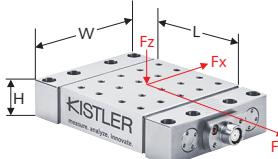

# Multi-component Dynamometers / Force Measurement Platforms

Technical Data		Type	9119AA1	9119AA2	9129AA
					
Measuring range	Fx, Fy	kN	-4 ... 4	-4 ... 4	-10 ... 10
	Fz	kN	-4 ... 4	-4 ... 4	-10 ... 10
	Mz	Nom			
Calibrated meas. ranges	Fx, Fy	kN	0 ... 0,04 0 ... 0,4 0 ... 4	0 ... 0,04 0 ... 0,4 0 ... 4	0 ... 0,1 0 ... 1 0 ... 10
	Fz	kN	0 ... 0,04 0 ... 0,4 0 ... 4	0 ... 0,04 0 ... 0,4 0 ... 4	0 ... 0,1 0 ... 1 0 ... 10
	Mz	N·m			
Natural frequency	$f_n(x)$	kHz	≈6,0	≈4,3	≈3,5
	$f_n(y)$	kHz	≈6,4	≈4,6	≈4,5
	$f_n(z)$	kHz	≈6,3	≈4,4	≈3,5
	$f_n(Mz)$	kHz			
Sensitivity	Fx	pC/N	≈-26	≈-26	≈-8
	Fy	pC/N	≈-13	≈-13	≈-4,1
	Fz	pC/N	≈-26	≈-26	≈-8
	Mz	pC/Nm			
Dimensions	L	mm	39	55	90
	W	mm	80	80	105
	H	mm	26	26	32
	D	mm			
Weight		kg	0,93	1,35	3,2
Operating temperature range		°C	-20 ... 70	-20 ... 70	-20 ... 70
Connector			Fischer flange, 9-pole, neg.	Fischer flange, 9-pole, neg.	Fischer flange, 9-pole, neg.
Deg. of protection to IEC/EN 60529 with cable connected		IP67	•	•	•
Ready for measurement			•	•	•
Datasheet: see <a href="http://www.kistler.com">www.kistler.com</a>			9119AA1 (003-060)	9119AA2 (003-055)	9129AA (000-709)

## Accessories

Connecting cable	Type	1687B5 (3-component), 1677A5 (6-component)	1687B5 (3-component), 1677A5 (6-component)	1687B5 (3-component), 1677A5 (6-component)
				
		1689B5 (3-component), 1679A5 (6-component)	1689B5 (3-component), 1679A5 (6-component)	1689B5 (3-component), 1679A5 (6-component)

<sup>1)</sup> depending on cover plate size and material

<sup>2)</sup> mounted on steel cover plate, 300×300×35 mm

9139AA

9255C

9257B

9272

9366CC...

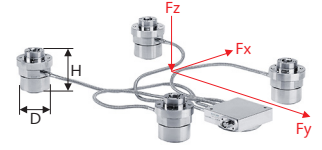
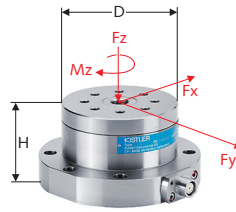
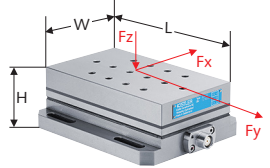
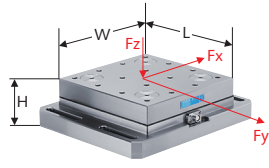
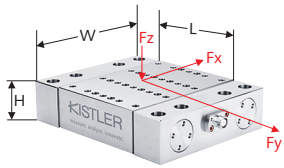

-30 ... 30  
-30 ... 30

-30 ... 30  
-10 ... 60

-5 ... 5  
-5 ... 10

-5 ... 5  
-5 ... 20  
-200 ... 200

-25 ... 25<sup>1)</sup>  
-25 ... 60<sup>1)</sup>

0 ... 0,3  
0 ... 3  
0 ... 30  
0 ... 0,3  
0 ... 3  
0 ... 30

0 ... 3  
0 ... 30  
0 ... 6  
0 ... 60

0 ... 0,5  
0 ... 5  
0 ... 1  
0 ... 10

0 ... 0,5  
0 ... 5  
0 ... 2  
0 ... 20  
0 ... ±20  
0 ... ±200

0 ... 2,5<sup>1)</sup>  
0 ... 25<sup>1)</sup>  
0 ... 6<sup>1)</sup>  
0 ... 60<sup>1)</sup>

≈2,9  
≈2,9  
≈3,0

≈2,2  
≈2,2  
≈3,3

≈2,3  
≈2,3  
≈3,5

≈3,1  
≈3,1  
≈6,3  
≈4,2

≈0,2 ... ≈1,6<sup>2)</sup>  
≈0,2 ... ≈1,6<sup>2)</sup>  
≈0,2 ... ≈1,6<sup>2)</sup>

≈-8,2  
≈-4,2  
≈-8,2

≈-7,9  
≈-7,9  
≈-3,9

≈-7,5  
≈-7,5  
≈-3,7

≈-7,8  
≈-7,8  
≈-3,5  
≈-160

≈-7,8  
≈-7,8  
≈-308

140  
190  
58

260  
260  
95

170  
100  
60

70  
100

90  
72

12,9

52

7,3

4,2

7

-20 ... 70

-20 ... 70

0 ... 70

0 ... 70

-20 ... 70

Fischer flange, 9-pole,  
neg.

Fischer flange, 9-pole,  
neg.

Fischer flange, 9-pole,  
neg.

Fischer flange, 9-pole,  
neg.

Fischer flange, 9-pole,  
neg.

•

•

•

•

•

•

•

•

•

9139AA (003-198)

9255C (003-051)

9257B (000-151)

9272 (000-153)

9366C (000-681)

1687B5 (3-component),  
1677A5 (6-component)

1687B5 (3-component),  
1677A5 (6-component)

1687B5 (3-component),  
1677A5 (6-component)

1677A5 (6-component)

1687B5 (3-component),  
1677A5 (6-component)

1689B5 (3-component),  
1679A5 (6-component)

1689B5 (3-component),  
1679A5 (6-component)

1689B5 (3-component),  
1679A5 (6-component)

1679A5 (6-component)

1689B5 (3-component),  
1679A5 (6-component)



# Strain Sensors.

Piezoelectric sensors from Kistler can be used for high-resolution measurements of the strains occurring on a structure.

To achieve this, the sensor is mounted in a suitable position. If an indirect force measurement is required, the sensor is calibrated. The relevant factors here are the geometry of the structure, the material's modulus of elasticity and the mechanical stress.

$$= \frac{F}{A} \text{ and strain} = \frac{\Delta l}{l_0}$$





Surface strain sensors are attached to the structure with the mounting screw. The structure's strain is transmitted to the measuring element through static friction.

Strain measuring pins need a cylindrical mounting bore in which the sensor is then inserted and preloaded. Kistler offers strain measurement sensors with axial and radial alignment to the axis of the bore hole.

## Benefits

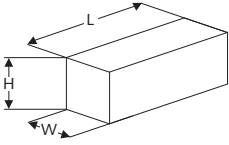
- Durable, no creep
- Protected against overload
- Cost-to-benefit ratio
- High loading capacity
- Simple to install
- Fault-resistant
- Straightforward retrofitting



# Surface Strain Sensor

Technical Data		Type	9232A...	9237B...	9238B...
					
Measuring range	$\mu$		-600 ... 600	-800 ... 800	-20 ... 20 to -800 ... 800
Calibrated meas. ranges*	$\mu$		0 ... -300 0 ... 300	0 ... 500	0 ... 50 0 ... 500
Sensitivity*	$\mu\text{C}/\mu$		$\approx -80$	$\approx -34$	
Output signal	V				$\pm 10$ (programmable $\pm 1 \dots 10$ )
Dimensions	L	mm	40	51,5	68,1
	W	mm	17	25,4	26,9
	H	mm	15	26,7	27,5
Natural frequency	$f_n$	kHz	$\geq 12$	$\geq 6$	
Weight	g		50	165/190	190
Operating temperature range	$^{\circ}\text{C}$		0 ... 70	-30 ... 120	-10 ... 70
Connector			KIAG 10-32 neg.	KIAG 10-32 neg.	M12x1 8-pole, shielded
Serial interface					RS-232C
Deg. of protection to IEC/EN 60529					
screwed with cable (e.g. 1631C...)	IP65		•	•	
welded with cable (e.g. 1983C...)	IP67		•		
screwed with cable (e.g. 1787A...)	IP67				•
Ready for measurement			•	•	•
<b>Datasheet: see <a href="http://www.kistler.com">www.kistler.com</a></b>			<b>9232A (000-137)</b>	<b>9237B (000-823)</b>	<b>9238B (000-822)</b>

\* Data valid only for the test setup used at Kistler.

For precise force measurements, the sensor must be recalibrated after it is mounted.

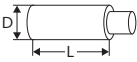
# Strain Measuring Pin

Technical Data		Type	9240A...	9241C...	
					
Measuring range	$\mu$		0 ... 500	0 ... 500	
Calibrated meas. ranges*	$\mu$		0 ... 200	0 ... 200	
Sensitivity*	pC/ $\mu$		$\approx -9,5$	$\approx -15$	
Dimensions	D	mm	8	10	
	L	mm	14,5	18	
Hollow preloading bolt					
Natural frequency	$f_n$	kHz			
Weight		g	34	38	
Operating temperature range		$^{\circ}\text{C}$	-40 ... 200	-40 ... 200	
Connector			acc. to choice: KIAG 10-32 pos. M3 pos.	acc. to choice: KIAG 10-32 pos. Mini-Coax neg.	
Deg. of protection to IEC/EN 60529 with connected cable with cable Type 1983AB... and welded-on plug		IP64	•	•	
		IP67			
<b>Datasheet: see <a href="http://www.kistler.com">www.kistler.com</a></b>			<b>9240A (003-229)</b>	<b>9241C (000-140)</b>	

## Accessories

Mounting tool	Type	1300A161A100	1393B
	Type	1300A163A300	1393Bsp100-300
Force distributing cap	Type		
Ground isolation set	Type		
Reamer	Type		
Screw tap	Type		

\* Data valid only for the test setup used at Kistler.  
For precise force measurements, the sensor must be recalibrated after it is mounted.

9243B...	9245B..., 9245B3	9247A...
----------	------------------	----------



-1500 ... 1500 (with nominal preload)	-1500 ... 1500 (with nominal preload)	-1400 ... 1400 (with nominal preload)
0 ... 350	0 ... 350	not calibrated
≈ -15	≈ 15	≈ 8,6
8 13	M10×1 29	M5×0,5 23,7
M10×1		
>110	>50	
4,8 (without cable and preloading screw)	36	2,5
-40 ... 200	-40 ... 350	-40 ... 200
M4×0,35 neg.	Fischer KE 102 neg.	M4×0,35 neg.
• •	•	• •
9243B (000-538)	9245B (000-142)	9247A (000-143)

1385A200		1300A9
1385sp100-800 / 1387sp100-800		
9841		
9487A		
1300A21	1300A21	1300A79 / 1300A79Q01
		1357A



# 1-Component Strain Gage Force Sensors

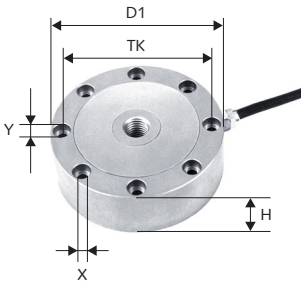

Type 4576A...

Technical Data		Type	4576A0,5...	4576A1...	4576A2...
Measuring range	Fz	kN	-0,5 ... 0,5	-1 ... 1	-2 ... 2
Dimensions	H	mm	16	16	16
	D1	mm	54,5	54,5	54,5
	TK	mm	45	45	45
	X	mm	4,5	4,5	4,5
	Y	mm	8	8	8



Technical Data		Type	4576A5...	4576A10...	4576A20...
Measuring range	Fz	kN	-5 ... 5	-10 ... 10	-20 ... 20
Dimensions	H	mm	16	16	25
	D1	mm	54,5	54,5	79
	TK	mm	45	45	68
	X	mm	4,5	4,5	4,5
	Y	mm	8	8	8

Technical Data		Type	4576A50...	4576A100...	4576A200...
Measuring range	Fz	kN	-50 ... 50	-100 ... 100	-200 ... 200
Dimensions	H	mm	35	50	50
	D1	mm	119	155	155
	TK	mm	105	129	129
	X	mm	6,6	13,5	13,5
	Y	mm	11	20	20

## General Technical Data

Nominal sensitivity	mV/V	1,5 (optional: 1,0)
Weight	Kg	0,25 ... 5,0
Operating temperature range	°C	15 ... 70
Service temperature range	°C	-30 ... 80
Bridge resistance	Ω	350
Connector for maXYmos family		D-Sub 9-pole plug
Deg. of protection to IEC/EN 60529		IP52 (0 ... 10 kN) IP67 (20 ... 200 kN)
Datasheet: see <a href="http://www.kistler.com">www.kistler.com</a>		4576A (000-675)

## Accessories

Connecting cable, 5 m, 6-pole/6-pole	Type	KSM071860-5
		
Connecting cable, 5 m, 6-pole/free	Type	KSM103820-5
		

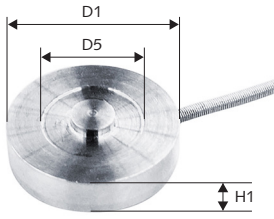

Type 4577A...

Technical Data			Type	4577A0,1	4577A0,2	4577A0,5	4577A1
Measuring range	Fz	kN		0,1	0,2	0,5	1
Bridge resistance		$\Omega$		350	350	350	350
Dimensions	H1	mm		9,9	9,9	9,9	9,9
	D1	mm		31,8	31,8	31,8	31,8
	D5	mm		19	19	19	19



Technical Data			Type	4577A2	4577A5	4577A10	4577A20
Measuring range	Fz	kN		2	5	10	20
Bridge resistance		$\Omega$		350	700	700	700
Dimensions	H1	mm		9,9	9,9	9,9	16
	D1	mm		31,8	31,2	31,2	37,6
	D5	mm		19	19,5	19,5	25,7

Technical Data			Type	4577A50	4577A100	4577A200
Measuring range	Fz	kN		50	100	200
Bridge resistance		$\Omega$		700	700	350
Dimensions	H1	mm		16	25,4	38,1
	D1	mm		37,6	50,3	76,2
	D5	mm		25,7	34,7	45

**General Technical Data**

Nominal sensitivity	mV/V		1
Weight	Kg		0,04 ... 1,2
Operating temperature range	$^{\circ}\text{C}$		15 ... 70
Service temperature range	$^{\circ}\text{C}$		-20 ... 100
Connector for maXYmos family			D-Sub 9-pole plug
Deg. of protection to IEC/EN 60529			IP64
Datasheet: see <a href="http://www.kistler.com">www.kistler.com</a>			4577A (000-674)

**Accessories**

Connecting cable, 5 m, 6-pole/6-pole	Type	KSM071860-5
		
Connecting cable, 5 m, 6-pole/free	Type	KSM103820-5
		

# 1-Component Strain Gage Force Sensors

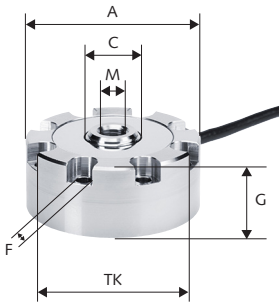

Type 4579A...

Technical Data			Type	4578A0,1	4578A0,2	4578A0,5
Measuring range	Fz	kN		-0,1 ... 0,1	-0,2 ... 0,2	-0,5 ... 0,5
Dimensions	A	mm		70	70	70
	C	mm		20	20	20
	F	mm		6,4	6,4	6,4
	M	mm		M12	M12	M12
	G	mm		28	28	28
	TK	mm		60	60	60

Technical Data			Type	4578A1	4578A2	4578A5
Measuring range	Fz	kN		-1 ... 1	-2 ... 2	-5 ... 5
Dimensions	A	mm		70	70	70
	C	mm		20	20	20
	F	mm		6,4	6,4	6,4
	M	mm		M12	M12	M12
	G	mm		28	28	28
	TK	mm		60	60	60

Technical Data			Type	4578A10
Measuring range	Fz	kN		-10 ... 10
Dimensions	A	mm		70
	C	mm		20
	F	mm		6,4
	M	mm		M12
	G	mm		28
	TK	mm		60

## General Technical Data

Nominal sensitivity	mV/V	2,0±0,005
Weight (without cable)	Kg	≤0,5
Operating temperature range	°C	15 ... 50
Service temperature range	°C	-20 ... 50
Bridge resistance	Ω	350
Connector for maXYmos family		D-Sub 9-pole plug
Deg. of protection to IEC/EN 60529		IP42
<b>Datasheet: see <a href="http://www.kistler.com">www.kistler.com</a></b>		<b>4578A (000-866)</b>

## Accessories

Force distributing cap	Type	4578AZ01
------------------------	------	----------

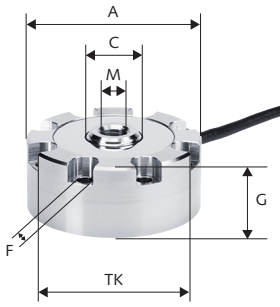

Type 4579A...

Technical Data			Type	4579A20	4579A50	4579A100
Measuring range	Fz	kN		-20 ... 20	-50 ... 50	-100 ... 100
Dimensions	A	mm		150	150	165
	C	mm		40	40	50
	F	mm		11	11	13
	M	mm		M24×2	M24×2	M36×3
	G	mm		40	40	42
	TK	mm		130	130	145

Technical Data			Type	4579A200	4579A300	4579A500
Measuring range	Fz	kN		-200 ... 200	-300 ... 300	-500 ... 500
Dimensions	A	mm		165	203	203
	C	mm		50	94	94
	F	mm		13	13	13
	M	mm		M36×3	M45×3	M45×3
	G	mm		42	64	64
	TK	mm		145	165	165

#### General Technical Data

Nominal sensitivity	mV/V	2,0±0,005
Weight (without cable)	Kg	3,7 ... 14,4
Operating temperature range	°C	15 ... 50
Service temperature range	°C	-20 ... 50
Bridge resistance	Ω	350
Connector for maXYmos family		D-Sub 9-pole plug
Deg. of protection to IEC/EN 60529		IP67
Datasheet: see <a href="http://www.kistler.com">www.kistler.com</a>		4579A (000-867)

#### Accessories

Force distributing cap, measuring range 20/50 kN	Type	4579AZ20/50
Force distributing cap, measuring range 100/200 kN	Type	4579AZ100/200
Force distributing cap, measuring range 300/500 kN	Type	4579AZ300/500

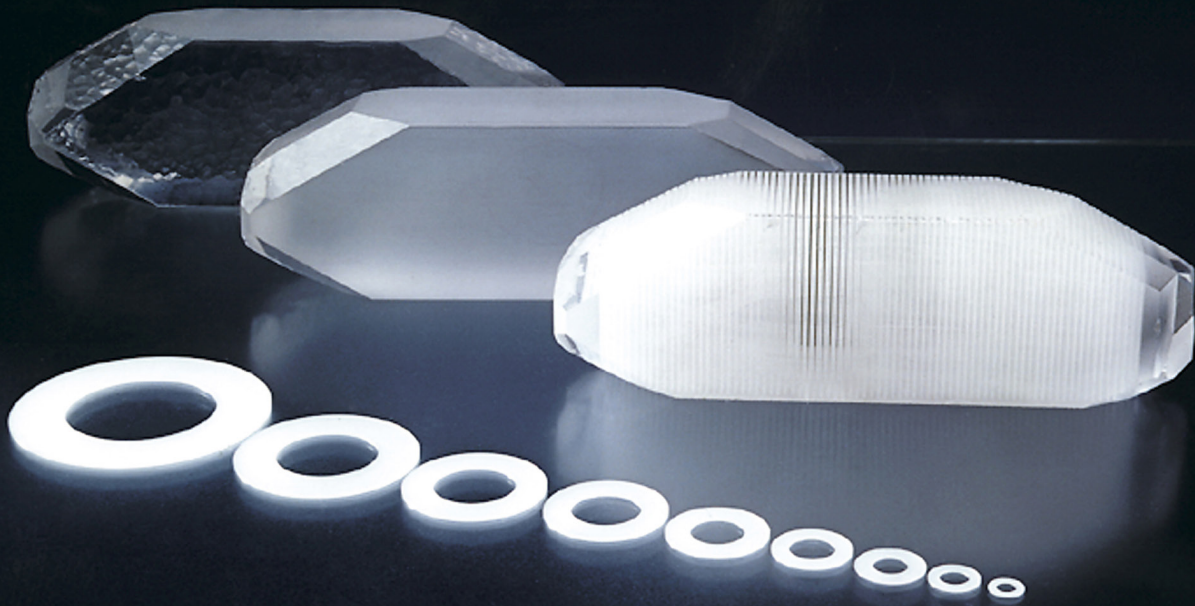

Most Kistler sensors operate with a measuring element that essentially consists of thin quartz plates, disks or rods

# Basics of Measurement Technology.

## Piezoelectric Measurement Technology

Kistler offers piezoelectric and strain gage sensors. The piezoelectric sensors are ideal for measuring tasks with exceptionally extreme requirements with regard to geometry, temperature range and dynamics. Kistler therefore relies mainly on the piezoelectric principle for measuring dynamic forces in assembly and testing.

Pierre and Jacques Curie discovered the piezoelectric effect in 1880. When placed under a mechanical load (Greek "pie-zein": to press or squeeze), piezoelectric materials generate electrical charges. The finite insulation resistance means that purely static measurements are impossible with piezoelectric sensors. Together with signal conditioning devices from Kistler, however, these sensors have excellent quasistatic and dynamic measurement properties.

In 1950, Walter P. Kistler patented the charge amplifier for piezoelectric signals, paving the way for the exploitation of an effect that had been known for decades.

Particularly good use can be made of the piezoelectric effect with a quartz crystal: when subject to a mechanical load, it generates a charge signal that is directly proportional to the acting force. The benefit: due to the high rigidity of the crystal, the measuring deflection is low. Quartz can be used to cut both pressure-sensitive and shear-sensitive elements. Various piezo-effects are differentiated according to the position of the polar crystal axes in relation to the acting force:

- Longitudinal effect
- Shear effect
- Transverse effect

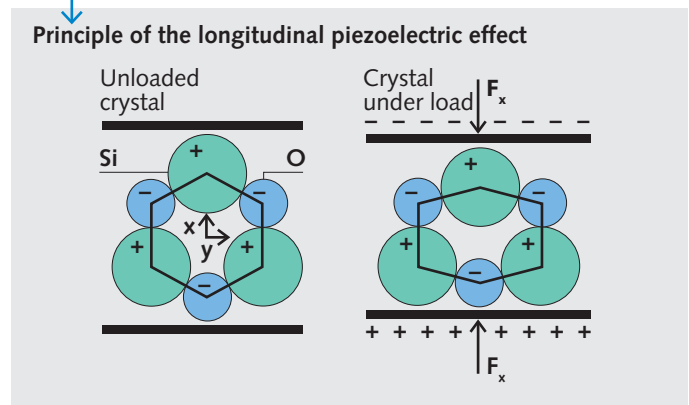
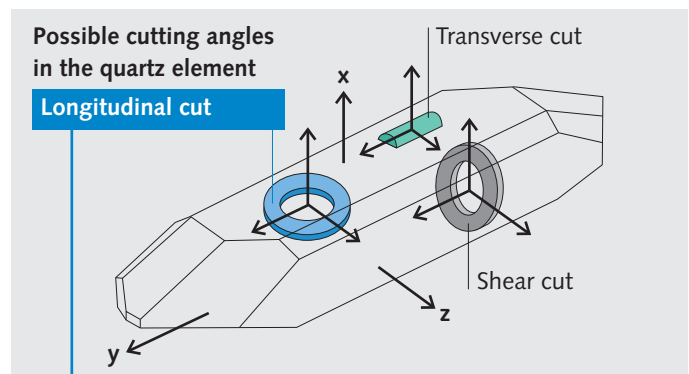

- Benefits**
- Compact size
  - Extensive force measuring range
  - Excellent overload protection
  - No wear
  - High rigidity and natural frequency
  - Measurements without almost any deflection are possible

### Longitudinal Effect

A charge is developed on the surfaces to which the force is applied, where it can be measured via electrodes. In the case of the longitudinal piezoelectric effect, the magnitude of the electric charge  $Q$  depends on the piezoelectric coefficient and the applied force  $F_x$  and not on the dimensions of the crystal disks. The only way to increase this charge yield is to connect several disks mechanically in series and electrically in parallel (factor  $n$ ). The magnitude of the output charge then becomes:

$$Q_x = d_{11} \cdot F_x \cdot n$$

The piezoelectric coefficient  $d_{11}$  is dependent on direction, and it indicates the crystal's degree of force sensitivity in the direction of the corresponding crystallographic axis. The position of the crystal cut therefore determines the properties and purpose of use the quartz force link. Piezoelectric elements cut to produce the longitudinal effect are sensitive to compression forces and therefore mainly suitable for simple and sturdy sensors to measure forces.

### Shear Effect

Similarly to the longitudinal effect, the piezoelectric sensitivity involved in the shear effect is independent of the size and shape of the piezoelectric element. In this case too, the charge is developed on the piezo element's loaded surfaces. For a load in the x-direction applied to  $n$  elements connected mechanically in series and electrically in parallel, the charge is:

$$Q_x = 2 \cdot d_{11} \cdot F_x \cdot n$$

Shear-sensitive piezo elements are used for sensors measuring shear forces, torque and strain, and also for acceleration sensors. They are suitable for manufacturing sensors whose excellent performance is unaffected by temperature fluctuations, as the changes in the stresses (preloading) in the sensor structure – caused by temperature fluctuations – act in a direction perpendicular to the sensitive shear axis.

### Transverse Effect

In the transverse effect, a force  $F_y$  acting in the direction of one of the electrical crystal axes  $y$  produces a charge on the surfaces of the corresponding electrical axis  $x$ . In contrast to the longitudinal piezoelectric effect, the magnitude of this charge (which occurs on the unloaded surfaces) is dependent on the geometric dimensions of the piezoelectric element. Assuming a solid rectangular element with dimensions  $a$  (thickness) and  $b$  (height/length), the charge is:

$$Q_y = -d_{11} \cdot F_y \cdot b/a$$

The transverse effect therefore makes it possible to obtain a greater charge yield through suitable shaping and alignment of the piezoelectric elements. Elements exhibiting this effect can be used for high-sensitivity pressure, strain and force sensors.

### Block diagram of a measuring chain

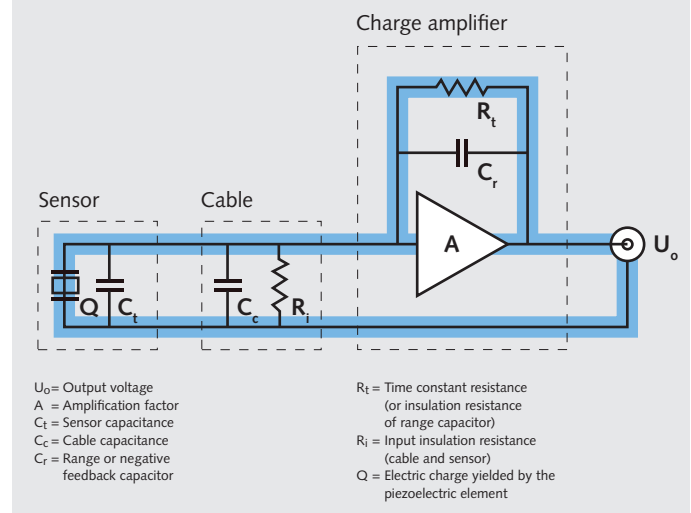

### Charge Amplifiers

Charge amplifiers convert the charge produced by a piezoelectric sensor into a proportional voltage:

$$U_o = \frac{-Q}{C_r} \cdot \frac{1}{1 + \frac{1}{A \cdot C_t} (C_t + C_r + C_c)}$$

the amplifier acts as an integrator, constantly compensating the electrical charge produced by the sensor on the range capacitor, in proportion to the acting measurand. Most Kistler charge amplifiers allow adjustment of sensor sensitivity and measuring range.

### Time constant and drift

Two of the more important considerations in the practical use of charge amplifiers are the time constant and the drift. The time constant is defined as the discharge time of a capacitor by which  $1/e$  (37 %) of the initial value has been reached:

$$= R_t \cdot C_t$$

Drift is defined as an undesirable change in the output signal over a long period of time. This drift determines the potential duration of quasistatic measurements.



# Measuring Methods

Kistler's sensors allow both direct and indirect force measurements. This permits flexible positioning of the sensors, so solutions are available for every conceivable measuring task.

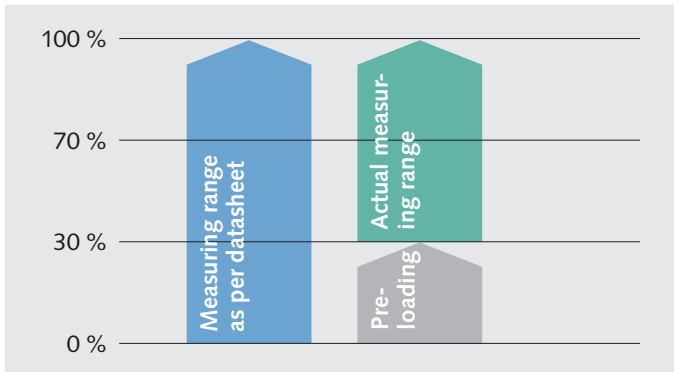

## Preloading

To achieve measurements of the desired accuracy, piezoelectric sensors are preloaded by 20 % to 70 % for symmetrical compression

and tensile forces, depending on their design and application. Therefore, the resultant measuring range actually corresponds to the total measuring range stated on the datasheet less the preloading value.

## Installation variants

For direct measurements, the sensor is positioned fully in the force flux, and it measures the entire force. This approach yields high measurement accuracy that is virtually independent of the force application point. If the sensor cannot be positioned directly in the force flux, it will only measure part of the force; the remainder passes through the structure in which it is mounted (known as the force shunt). With indirect force measurement, strain sensors are used to measure the process force via the structural strain. The deformation resulting from application of force to a structure can be measured as force-proportional strain. The process force is therefore determined indirectly from the surface or structural strain. Kistler strain sensors internally convert strain into a proportional force, and generate a corresponding charge signal. This is why they are often referred to as force-strain sensors. The sensitivity is determined as electric charge  $Q$  (pC) per unit strain  $\mu$  ( $\mu\text{m}/\text{m}$ ).

**Direct Force Measurement in the Force Flux**  
 In this case, the entire process force passes through the sensor (force shunt quota  $n < \approx 10\%$ ).  
 The sensor is mounted fully in the force flux and it measures the entire process force.

**Benefits**

- High sensitivity
- High measuring accuracy
- High repeatability
- Good linearity and low hysteresis
- Wide range of preloaded calibrated sensors that are easy to mount

**Force Shunt Measurement**  
 A fraction of the process force passes through the sensor ( $n \approx 10 \dots 99\%$ ).  
 The sensor is installed in the machine's structure. Most of the process force usually passes into the shunt.

**Benefits**

- Overload protection
- Cost-effective design
- Measurement of process forces up to  $100/(100-n)$  times the sensor's measuring range
- Good measurement accuracy under constant conditions
- High repeatability

**Indirect Force Measurement**  
 Only a negligible part of the process force passes through the sensor ( $n \gg 99\%$ ).

**Benefits**

- Most convenient mounting method
- Easily retrofitted on existing machines
- Overload protection
- Cost-effective design

# Strain Gage Measurement Technology

The principle of operation of the strain gage is based on a physical effect: the electrical resistance of a wire changes in proportion to any change in length caused by stretching or compression. Kistler uses this principle to measure the torque on rotating shafts and in some force sensors.

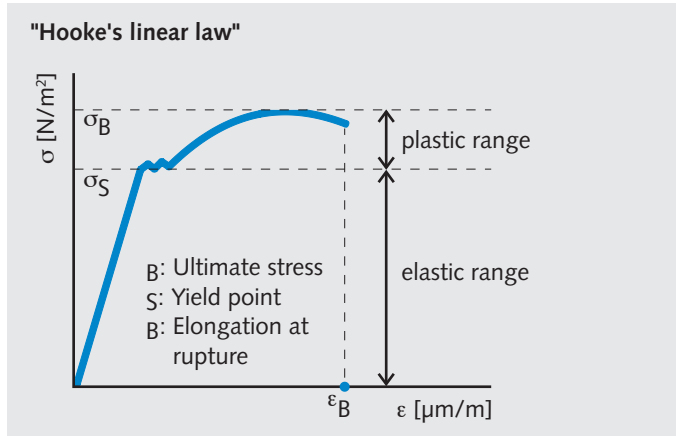

Strain gages measure the deformation of structures in the linearly elastic range.

## Principle of Operation

When the measuring wire undergoes a strain  $\epsilon$ , its length  $L$ , cross-sectional area  $A$  and specific resistance  $\rho$  will change. The wire is commonly replaced with thin ( $\approx 0,005$  mm) metallic foil from which a meandrous pattern is etched to form a measuring grid. This produces strain gages with very small dimensions (e.g.  $1 \times 1$  mm measuring grids) capable of measuring at an almost exact point.

## Force Detectors

For use in strain gage load sensors, the gages are bonded onto a force detector made of a very strong material that exhibits linearly elastic characteristics up to the rated load. This means that the mechanical stress  $\sigma$  produced by the load on the force detector is linearly related to the strain  $\epsilon$  according to Hooke's law:

$$\sigma = E \cdot \epsilon$$

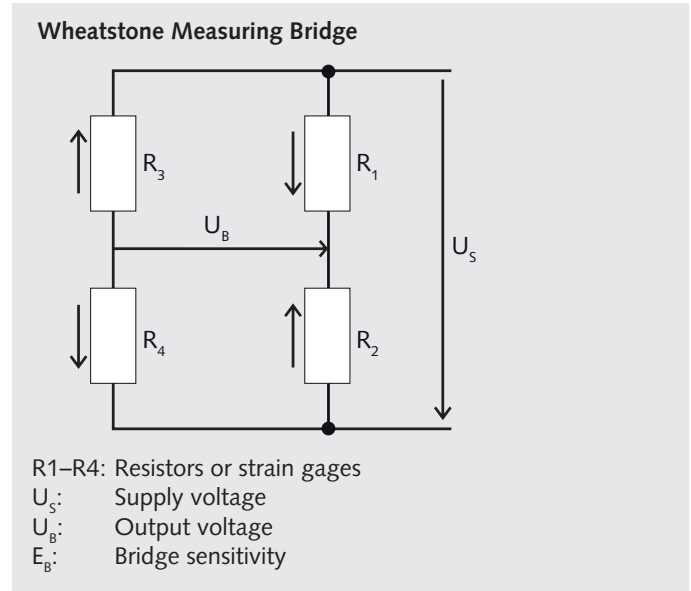

## Wheatstone Measuring Bridge

This measuring bridge consists of four resistors or strain gages. It is supplied with voltage  $U_S$ . The output voltage  $U_B$  is taken off the middle of the bridge. The sensitivity of the bridge  $E_B$  gives the relationship between output voltage with gage factor ( $k$ ) and strain  $\epsilon$ .

$$E_B = \frac{U_B}{U_S} = k \cdot \epsilon$$

Full bridges are almost always used for strain gage sensors. The bridge is generally supplemented by other resistors to compensate for various factors.

## Measuring Chain with Strain Gages

The voltages produced by the bridge are in the range of a few mV. The leads for the unamplified analog signals are kept as short as possible to minimize the effect of any electromagnetic fields. A differential amplifier generally amplifies and then digitizes the voltage. Such amplifiers have a very high input resistance and high common-mode rejection.

## Benefits of Strain Gage Sensors

- Allow tensile and compression measurements without having to preload measuring elements
- Static measurements are possible over long periods of time
- Absolute measurement values

# Measuring Chains.

In order to integrate sensor technology into a given application, it is necessary to clarify these points in order to provide the basis for selecting the relevant components to generate the measuring chain:

- Measuring range and mode: direct, indirect, and technology
- Ambient conditions: temperature, gases and liquids, mechanics
- Signal analysis with Kistler instrument or using customer's system

Ideally, the measurand should be captured as close to the process as possible; the easiest way to implement this is with a preloaded and calibrated sensor. Load washers and strain sensors are calibrated in the installed condition.

The high-insulation cable, with a typical insulation value  $>1E13$  Ohm, is a particularly important element of piezoelectric measuring technology, and it should be selected according to the ambient conditions.

After conversion of the sensor signals, they can be evaluated by an amplifier in the customer's system. For the analysis of dedicated XY processes (such as force-displacement monitoring), the maXYmos family is highly suitable thanks to its user-friendly operation and wide variety of interfaces (Y-channel: piezo, strain gage,  $\pm 10V$ ; X-channel: potentiometer,  $\pm 10V$ , incremental).

Measure

Connect

Amplify

Monitor & Control

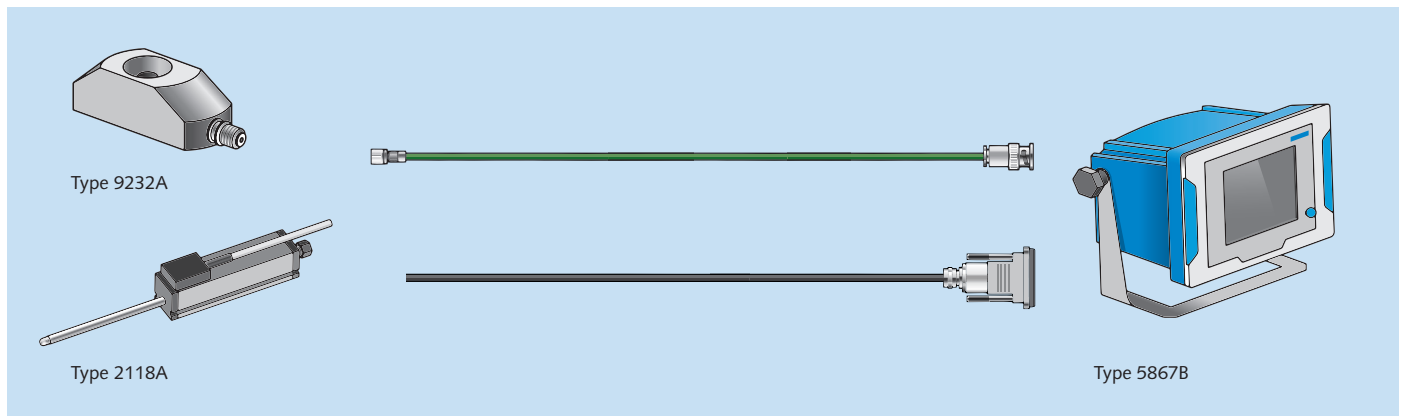
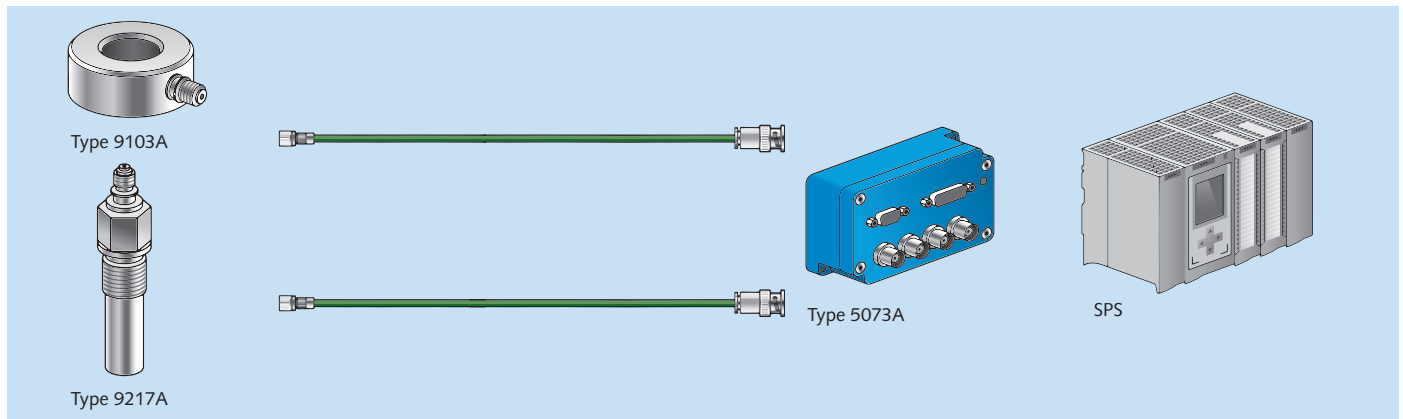

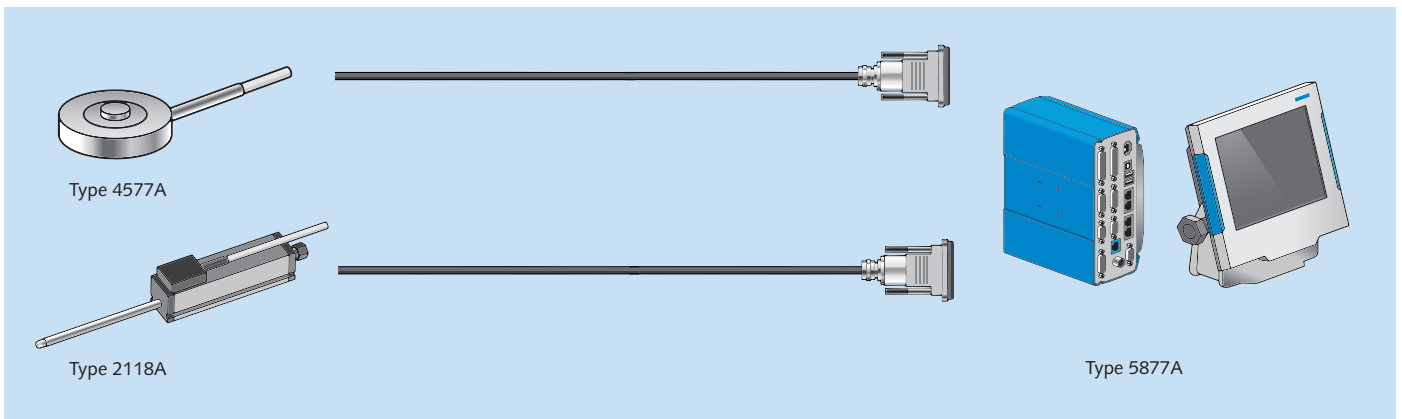
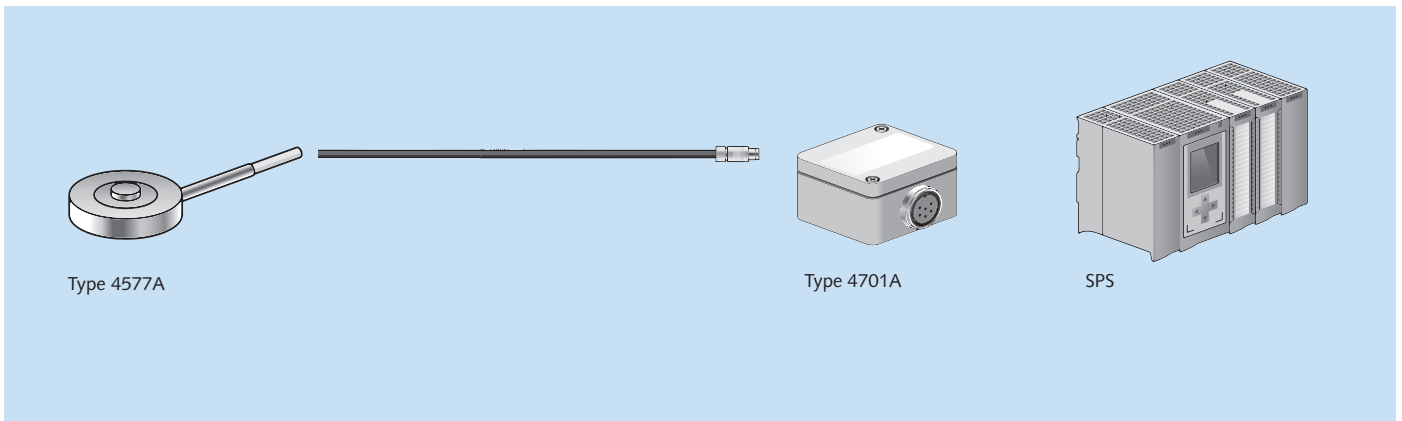
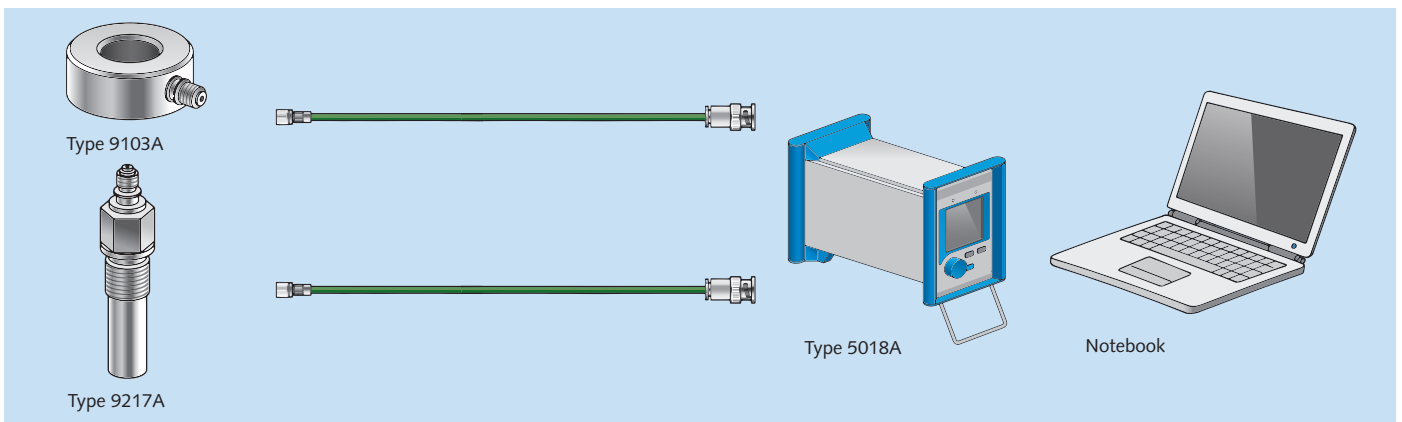
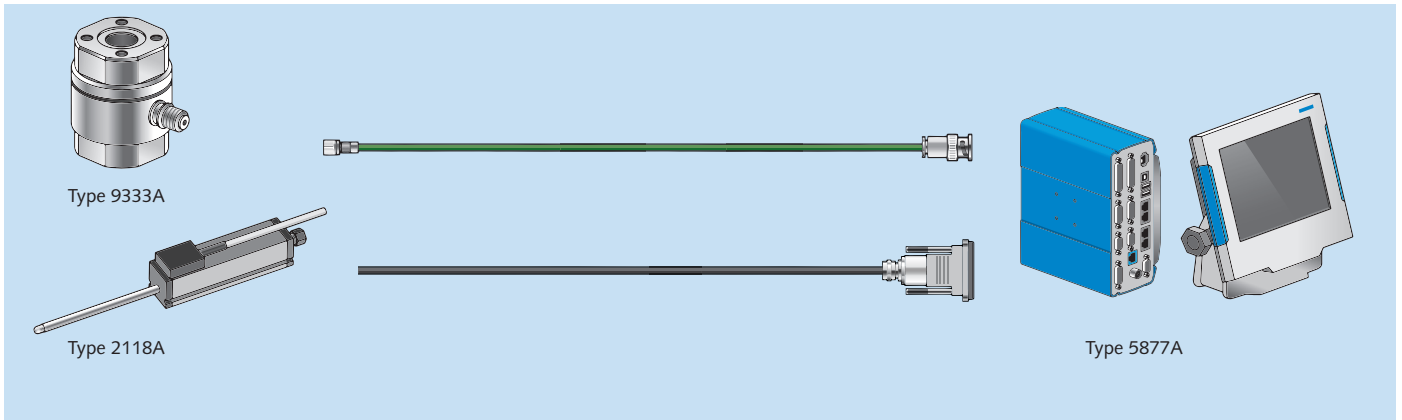





Sensors must be meticulously calibrated in order to guarantee reliable measurement results

# Calibration.

**Sensors and measuring instruments must be calibrated at regular intervals, as their characteristics and hence the measurement uncertainties can change over time as a result of frequent use, aging and environmental factors. Instruments used for calibration are traceable to national standards and subject to a uniform international quality control. Calibration certificates document calibration values and conditions.**

## Safe and Reliable Measurements

Quality assurance systems and product liability laws call for systematic monitoring of all test equipment needed for measuring quality characteristics. This is the only way to ensure that measurement and test results provide a reliable and dependable benchmark for quality control.

All sensors and electronic measuring devices are subject to some degree of measurement uncertainty. As the deviations involved can change over time, the test equipment must be calibrated at regular intervals.

This involves determining the deviation of the measured value from an agreed reference value, which is also referred to as the

calibration standard. The result of a calibration can either be used to assign the actual values of the measurand to the readings or to determine correction factors for them. The required information is documented on the calibration certificate.

**Definition: Calibration is the use of a defined method under specified conditions to determine the relationship between a known input variable and a measured output variable.**

## Principle of Sensor Calibration

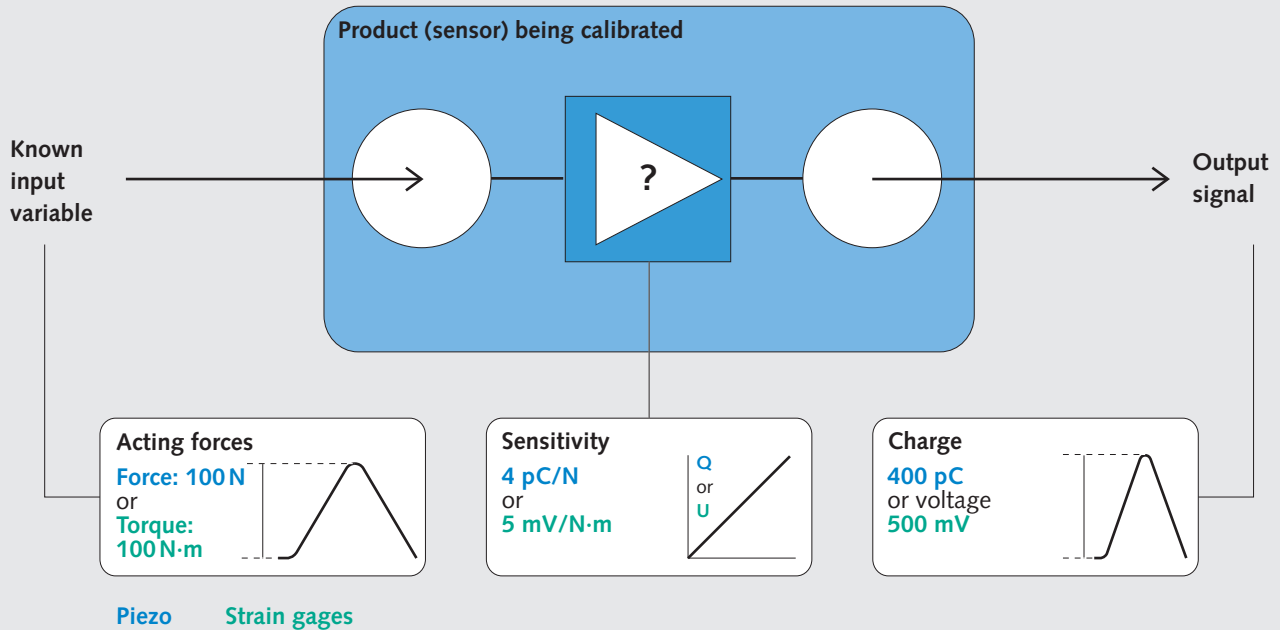

### Calibration Process

During calibration, sensors are subjected to known quantities of a physical measurand (such as force) and the corresponding values of the output variable are recorded. The magnitude of this load is accurately known, as it is measured with a traceably calibrated "factory standard" at the same time. Depending on the method, sensors are calibrated either across the entire measuring range or in a partial range:

- at a single point,
- continuously, or
- stepwise at several different points.

### Strain Gage Calibration

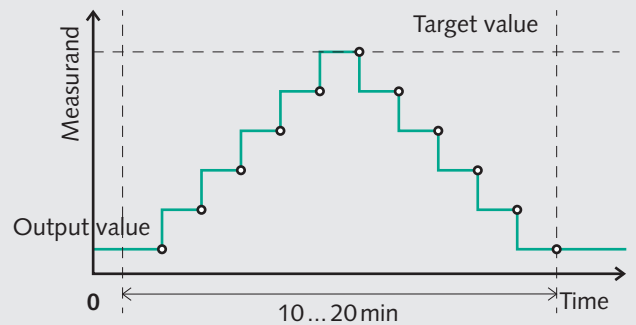

### Piezo Calibration

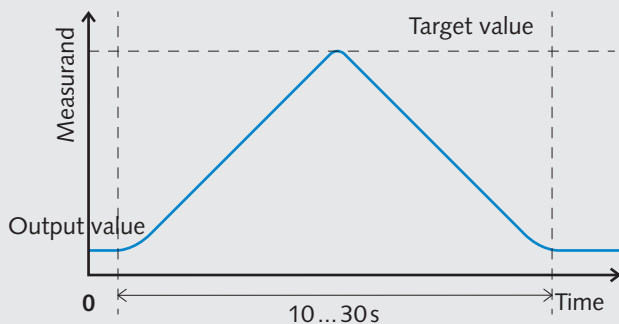

During **continuous calibration**, the load is continuously increased to the required value within a defined time and then reduced to zero within the same time. A "best straight line" passing through the origin is defined for the resultant characteristic, which is never exactly linear. The gradient of this line corresponds to the sensitivity of the sensor within the calibrated measuring range.

**Step-by-step calibration** involves the application of a load with or without unloading between successive increases or decreases, depending on the calibration method used. The process is halted after each increment until the measurement stabilizes.

Linearity is determined by the deviation of the characteristic from the best straight line. Hysteresis corresponds to the maximum difference between the rising and falling characteristics. Most Kistler single- or multiaxial force and torque sensors are factory calibrated.

The continuous approach is the most suitable calibration method for piezoelectric sensors. Strain gage sensors are preferably calibrated step-by-step.

Kistler offers diverse calibration options:

- The sensor equipment can be sent to the production plant
- Onsite calibration in the plant
- Calibration equipment for in-house calibration





From professional advice on installation to speedy deliveries of spare parts: Kistler's comprehensive range of services and training is at your disposal across the globe

# Service: Customized Solutions from A to Z.

Kistler offers sales and service wherever automated manufacturing processes take place.

In addition to sensors and systems, Kistler offers a host of services – from professional advice on installation to speedy worldwide deliveries of spare parts. For an overview of the services we offer, visit [www.kistler.com](http://www.kistler.com). For detailed information on our training courses, please contact our local distribution partners (see page 51).

## Kistler Service at a Glance

- Advice
- Support with system commissioning
- Process optimization
- Periodic onsite calibration of sensors
- Education and training events
- Development services

# Kistler – At Our Customers' Service Across the Globe.

With around 1500 employees, the Kistler Group leads the global market for dynamic measuring technology. 31 group companies and over 30 distributors ensure close contact with customers, individual application support and short delivery times.

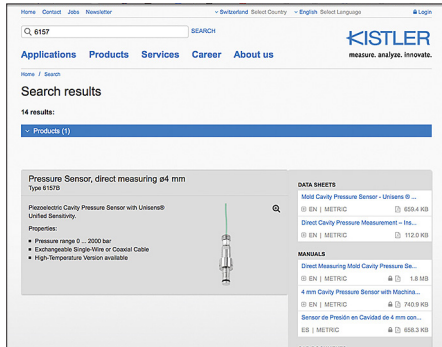

## Datasheets and Documents

Use our search engine to download datasheets, brochures or CAD data.

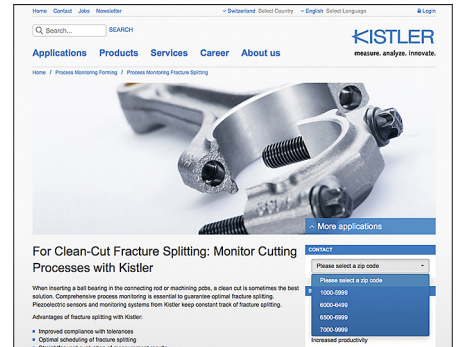

## Your Contacts

No matter whether you come to us for advice or for support with an installation – on our website, you will find the contact details for your personal partner anywhere in the world.

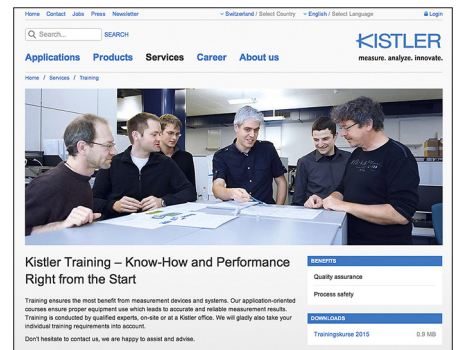
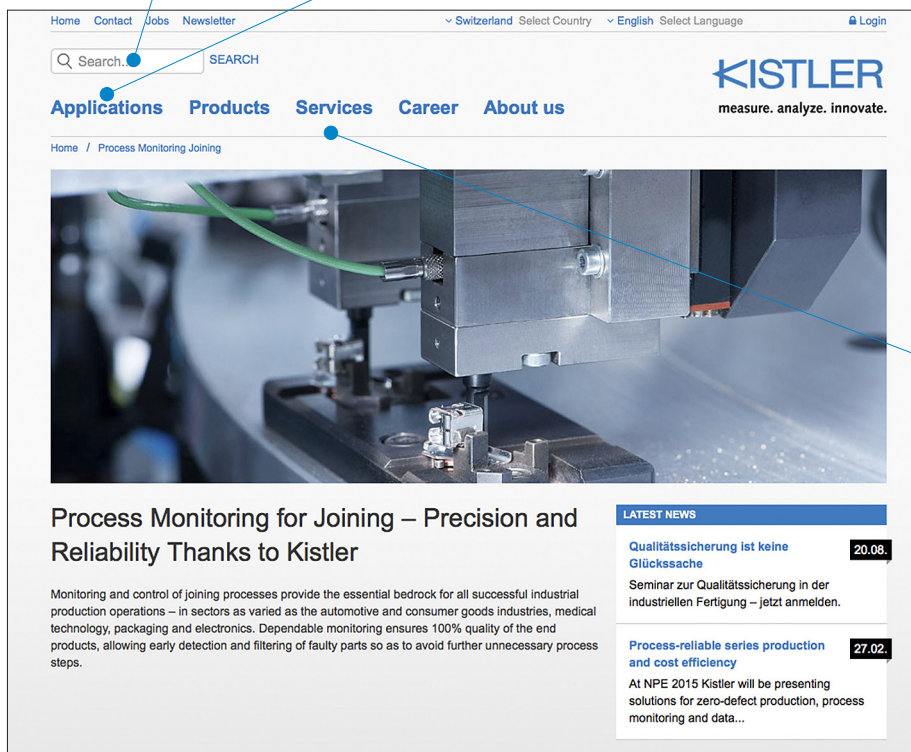

## Education and Training Events

Education and training courses – when our sensors and measuring systems are explained by experienced Kistler experts – are the most efficient way for you to acquire the expertise you need.

**Kistler Group**

Eulachstrasse 22

8408 Winterthur

Switzerland

Tel. +41 52 224 11 11

Kistler Group includes the Kistler Holding AG and all its subsidiaries in Europe, Asia, Americas and Australia.

Find your local contact at  
[www.kistler.com](http://www.kistler.com)

**KISTLER**  
measure. analyze. innovate.