

2790

SourceMeter® Airbag Test System



- Single-instrument solution for continuity and hi-pot type leakage resistance measurements
- Programmable constant V source (50–500V) supports high speed, high resistance measurements
- Programmable constant I source (0–50mA) with dry circuit clamp helps prevent device stress or damage during low resistance measurements
- Modular architecture adapts easily to single or dual inflator testing and to single or dual position test stands and mixed device/signal applications
- Expandable multiplexer channels for multipin applications
- Included 6½-digit DMM with wide functionality and broad measurement ranges
- Intelligent automation support and easy integration with external test hardware
- GPIB, RS-232, and digital I/O interfaces for flexible controller options
- SCPI programmable for simple code development and future extensions
- 2-year calibration cycle of modules minimizes maintenance costs and system downtime

The Model 2790 SourceMeter Switch System is a high voltage, multichannel resistance measurement solution that speeds and simplifies electrical checks of airbag inflators and a variety of other automotive electrical test applications. It is the only commercial instrument that combines all the sourcing, measurement, and signal routing capabilities required to measure insulation resistance and conductor continuity in one compact, affordable package. Through the use of plug-in source/switch modules, the Model 2790 provides programmable high voltage and low current sourcing, plus multichannel switching support. This unique combination of capabilities establishes a new standard for price and performance in airbag inflator and other test applications.

Measure Extreme Resistances with Constant Current or Constant Voltage

The Model 2790 uses the forced constant-current method to measure resistances less than 1kΩ. In this technique, the instrument sources a constant current (I) to the resistance and measures the resulting voltage (V). The amount of current sourced is programmable from 0–50mA. Resistance (R) is calculated (and displayed) using the known current and measured voltage ($R = V/I$). A 20mV dry circuit clamp is available at sourcing levels up to 1mA for preserving the oxide layers on connectors and other components.

For the 1MΩ to 1GΩ resistance ranges, the forced constant-voltage method is used to measure high resistance. This technique optimizes settling speed and reduces noise, allowing faster, high quality insulation resistance measurements. In addition, by applying high voltages (50–500V), the Model 2790 stresses a dielectric while simultaneously measuring its insulation resistance.

In addition to the resistance measurement functions available through the plug-in source/switch modules, the Model 2790's built-in DMM allows it to make a full range of high precision resistance measurements, as well as AC/DC voltage and current, frequency, and temperature measurements. These DMM functions are available through either front panel jacks or through the addition of a Model 7702 40-channel scanner module. In addition to the shorts/open testing performed with the standard Model 7751, 7752, and 7753 switch/control modules, a wide range of supporting measurements can be made. These supporting measurements simplify creating integrated test solutions for hybrid applications, such as testing complex automotive seating systems, which increasingly combine airbag inflators and seat-belt pre-tensioners, seat heaters, switches, motors, etc.

Newly Enhanced Memory Pattern Test Sequencer

The memory pattern test sequencer allows the mainframe to store and execute pre-programmed test sequences for increased testing throughput. Test setups can be stored as unique memory locations and either recalled by number as needed or scanned in sequence to maximize the number of tests per unit time without command transfer delays due to communication or controller.

ACCESSORIES AVAILABLE

MODULES

7702	40-Channel General Purpose Multiplexer Module
7751	High Voltage Source/Switch Module
7752	Low Voltage, Current-Source-Only Source/Switch Module
7753	1MΩ High Voltage Source/Switch Module (The Model 2790 supports only one Model 7753.)

COMMUNICATION INTERFACES AND CABLES

7007-1	Shielded IEEE-488 Cable, 1m (3.3 ft.)
7007-2	Shielded IEEE-488 Cable, 2m (6.6 ft.)
7009-5	Shielded RS-232 Cable
KPCI-488LP	IEEE-488 Interface/Controller for the PCI Bus
KPXI-488	IEEE-488 Interface Board for the PXI Bus
KUSB-488A	IEEE-488 USB-to-GPIB Interface Adapter

RACK MOUNT KITS

4288-1, -2	Single or Dual Fixed Rack Mount Kit
------------	-------------------------------------

OTHER

2790-EW	1 Year Extended Warranty
8503	Trigger Link Cable to 2 Male BNC Connector
8681	Miniature 4-Wire RTD, 100Ω

Multichannel resistance measurements for airbag inflator, harness, and connector testing

DIGITAL MULTIMETERS & SYSTEMS

1.888.KEITHLEY (U.S. only)

www.keithley.com

KEITHLEY

A GREATER MEASURE OF CONFIDENCE

2790

Ordering Information

2790-A	1M Ω single-module system for low and high voltage/resistance applications
2790-H	Single-module system for low and high voltage/resistance applications
2790-HH	Two-module system for low and high voltage/resistance applications
2790-HL	Two-module system for separating high and low voltage/resistance applications
2790-L	Single-module system for low voltage/resistance-only programmable current applications
7702	40-Channel Differential Multiplexer

Accessories Supplied

Reference and user manuals on CD-ROM, AC line power cord, mini flathead screwdriver.

APPLICATIONS

- Automotive airbag inflator/module electrical functional tests
- Seatbelt pre-tensioner actuator/module functional electrical check
- High speed, parallel soak, dual inflator, or dual test station electrical check
- Pinched wire, high voltage, insulation resistance testing in automotive seats, avionics, etc.
- Multipin connector/harness continuity and leakage resistance measurements
- Multicontact/switch dry circuit continuity and leakage tests
- Automotive power/fuse center continuity and leakage resistance characterization
- PCB/PWB and general purpose short/open circuits testing

SourceMeter® Airbag Test System

Match the System Configuration to the Application

The Model 2790 is available in a variety of configurations to match specific application requirements:

- The **Model 2790-H** is a single-module system designed for both low current and high voltage ohms (10M Ω to 1G Ω) applications. This “base” system provides all the capabilities needed for electrical testing of either single- or dual-stage inflators in single position test stands (for example, test stands that test only one single- or dual-stage airbag at a time).
- The **Model 2790-A**, which is similar to the Model 2790-H, enables high voltage ohms measurements down to 1M Ω .
- The **Model 2790-HH** is configured for applications that require parallel testing or high voltage “soaking.” Like the Model 2790-H, it is designed for both low current and high voltage ohms applications and can test either single- or dual-stage inflators. However, with two plug-in modules, it also has the capacity to test two inflators at once, maximizing test throughput.
- The **Model 2790-HL** is designed for applications where it is preferable to segregate high voltage sourcing/ohms measurement and low current sourcing/ohms measurement into two separate modules. This design was developed for use in combination testing applications, such as inflator electrical checks of safety steering wheel or seat assemblies that also include switch or other ancillary device tests.
- The **Model 2790-L** is configured for low voltage source/ohms-only measurement applications, such as continuity-only testing of side/seat airbags and seatbelt pre-tensioners or other programmable I-source resistance applications in which high voltage resistance testing is not required but precise control of source current is.
- With the addition of a Model 7702 40-channel differential multiplexer module (part of the Integra family of switch/measure solutions), the **Model 2790-A, -H, or -L + Model 7702** opens the door to higher channel count applications, such as hi-pot/continuity testing of connectors, harnesses, and power distribution devices up to 500V (internally sourced) up to 40 channels.

Broad Range of Measurement Capabilities

The Model 2790’s built-in DMM can make a wide variety of general purpose measurements:

- DC voltage measurements from 0.1 μ V to 1000V
- AC voltage measurements from 0.1 μ V to 750V
- DC current measurements from 10nA to 3A
- AC current measurements from 1 μ A to 3A
- 2-wire resistance measurements from 100 $\mu\Omega$ to 120M Ω
- 4-wire resistance measurements from 100 $\mu\Omega$ to 120M Ω
- Frequency measurements from 3Hz to 500kHz
- Period measurements from 333ms to 2 μ s
- Temperature measurements from -200°C to 630°C (thermistors and 4-wire RTDs)

Additional features of the Model 2790 mainframe include:

- Setup storage—Up to four instrument setups can be saved and recalled.
- Offset-compensated ohms—A two-measurement process for 4-wire ohms to cancel the effects of thermoelectric EMFs. Available for the 100 Ω , 1k Ω , and 10k Ω ranges.
- Math—m/X+b, mX+b, percent, and four special math functions provide convenient manipulation of raw readings.
- Relative—Null offsets establish baseline values.
- Ratio and channel average—Ratio and average calculations for two switching module channels (7702).
- Buffer—Store up to 55,000 readings in the internal buffer.
- Limits—Two sets of high and low reading limits to test devices.
- Digital I/O port—Five digital limit test output lines to control external circuitry. An external trigger input can also be accessed at this port.
- Trigger Link—Separate connector with input and output signals.
- Monitor—The Model 2790 can monitor a selected channel. A scan can be triggered to start when the monitor detects that a reading limit has been reached (7702).
- Remote interface—Model 2790 can be controlled using the IEEE-488 interface (GPIB) or the RS-232 interface.

1.888.KEITHLEY (U.S. only)

www.keithley.com

KEITHLEY

Example Application – Dual Stage Airbag Inflator Testing—One or Two

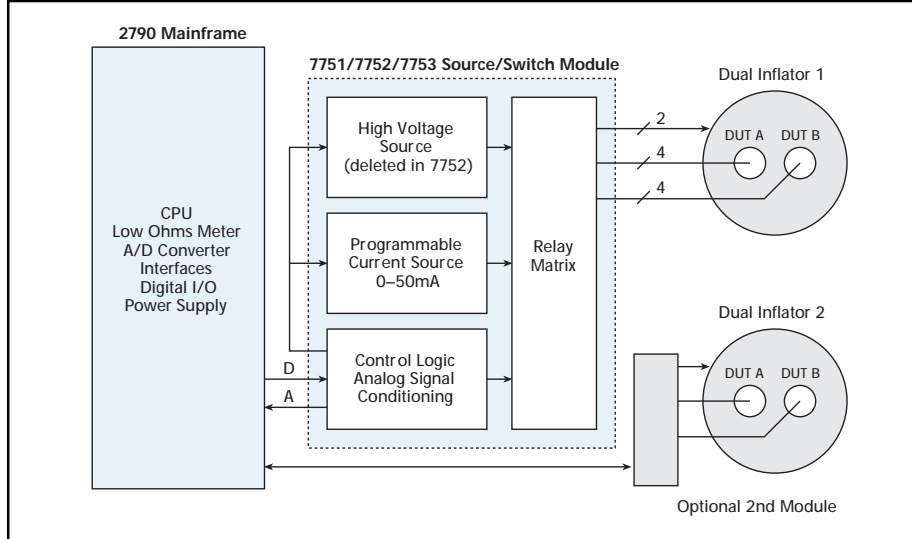

Example Application – 40-Channel Wiring Harness Testing

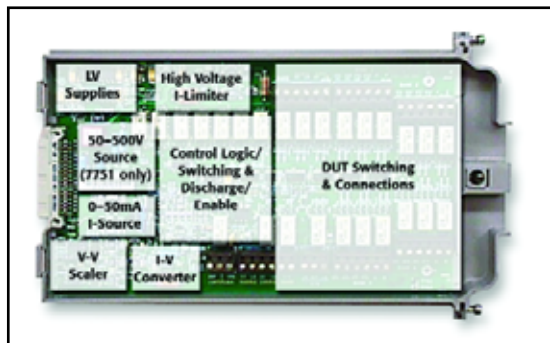
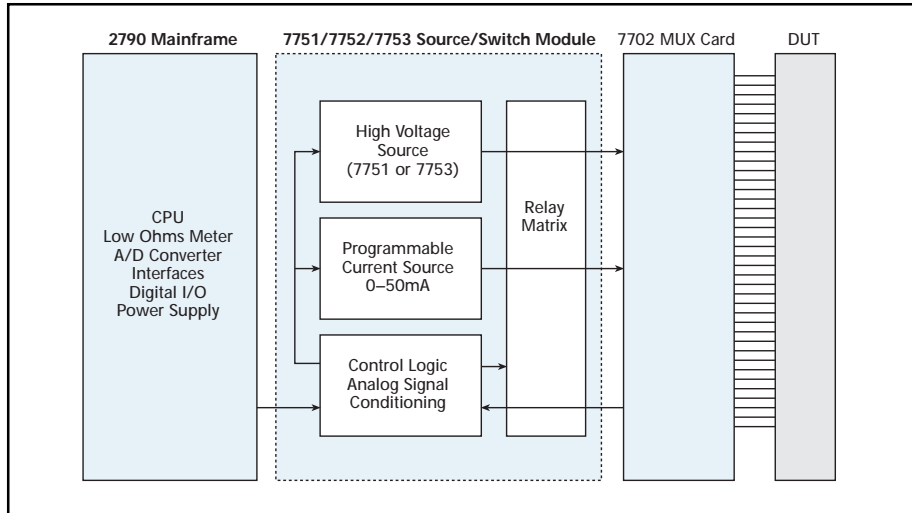

Three source/switch plug-in modules provide the Model 2790 with programmable high voltage and low current sources, connection switching, and signal conditioning circuitry.

Model 2790 Benefits

- **High functional integration**—Sourcing, measurement, and signal routing functions are tightly integrated in one compact enclosure. This high level of integration helps system integrators save rack space, minimize the time needed for system configuration and maintenance, and improve test throughput without sacrificing system accuracy.
- **Enhanced device protection**—Compared to higher powered alternatives, the Model 2790's inherently lower power sources minimize the possibility of damaging sensitive devices under test through accidental overpowering. Automatic cold switching and active cable discharge circuitry reduce the chances for device damage still further, while the high precision DMM and A/D converter ensure high resolution and measurement accuracy.
- **Reliability**—The design of the Model 2790 is based on a proven Keithley technology platform. With a two-year calibration cycle for the module functions, it requires minimal maintenance over the life of the production test line. Its modular mainframe and plug-ins architecture makes module verification and calibration fast and convenient, simply by exchanging modules.
- **Value**—In addition to being a complete solution for airbag inflator testing and related applications, the Model 2790's fully functional, 6½-digit DMM supports a wide variety of general purpose DC and AC measurements.

Mainframe Specifications

Refer to the Model 2700 specifications on page 36.

Key Module Specifications*

Refer to module specifications on page 58.

SYSTEM THROUGHPUT

HIGH OHMS: 13 rdgs/s.

LOW OHMS: 9 rdgs/s.

* The Model 7751, 7752, and 7753 plug-in modules have a two-year calibration interval; mainframe-only functions have a one-year calibration interval (max). System warranty period is one year.

7751/7752/7753 SOURCE/SWITCH MODULE SPECIFICATIONS

2790 RESISTANCE MODE SPECIFICATIONS WITH CARDS ^{2, 3}

(Module function accuracy specifications are for 2 years, 23°C, ±5°C.)

SOURCE CURRENT	MAXIMUM RESISTANCE	TYPICAL OPEN CIRCUIT VOLTAGE	ACCURACY (4W) ±(% rdg. + ohms)	TEMPERATURE COEFFICIENT (0–18°C & 28–40°C) ±(%rdg. + ohms)/°C
50 mA	20 Ω	5.5 V	0.09% + 2 mΩ	0.002% + 3 mΩ
20 mA	50 Ω	5.5 V	0.11% + 5 mΩ	0.003% + 3 mΩ
10 mA	100 Ω	5.5 V	0.16% + 10 mΩ	0.004% + 3 mΩ
(Dry Circuit Ohms 1mA max with 7751, 7752, or 7753 card)				
1 mA	10 Ω	20 mV	1.10% + 50 mΩ	(0.026% + 3 mΩ)/°C

(7751 Only)

SOURCE VOLTAGE	RESISTANCE RANGE	MAXIMUM SHORT CIRCUIT CURRENT	ACCURACY ±(% rdg.)	TEMPERATURE COEFFICIENT (0–18°C & 28–40°C) ±(%rdg.)/°C
500 V	10 MΩ	<1 mA	0.8%	0.03%
500 V	100 MΩ	<1 mA	1.1%	0.05%
500 V	1 GΩ	<1 mA	4.0%	0.12%
50 V	1 MΩ	<1 mA	1.1%	0.04%
50 V	10 MΩ	<1 mA	1.1%	0.06%
50 V	100 MΩ	<1 mA	1.6%	0.13%

(7753 Only)

SOURCE VOLTAGE	RESISTANCE RANGE	MAXIMUM SHORT CIRCUIT CURRENT	ACCURACY ±(% rdg.)	TEMPERATURE COEFFICIENT (0–18°C & 28–40°C) ±(%rdg.)/°C
500 V	1 MΩ	<1 mA	0.8%	0.02%
500 V	10 MΩ	<1 mA	0.9%	0.03%
500 V	100 MΩ	<1 mA	1.3%	0.10%
500 V	1 GΩ	<1 mA	6.7%	0.27%
50 V	0.1 MΩ	<1 mA	1.1%	0.03%
50 V	1 MΩ	<1 mA	1.1%	0.04%
50 V	10 MΩ	<1 mA	1.3%	0.11%
50 V	100 MΩ	<1 mA	4.5%	0.30%

CURRENT SOURCE OUTPUT

OUTPUT LEVEL: Programmable 0 to 50mA (Ch. 27).

PROGRAMMING RESOLUTION: 10µA.

OUTPUT VOLTAGE: 5.5V ±10% compliance.

ACCURACY: ±(0.06% + 10µA) (2 year specification).

SETTLING TIME: 1ms to 0.1% of final value (typ.).

TEMPERATURE COEFFICIENT (0–18°C & 28–40°C): ±(0.001% + 0.25µA)/°C.

DRY CIRCUIT CLAMP (Ch. 24): 20mV ±10%, I_{source} ≤1mA.

VOLTAGE SOURCE OUTPUT (7751/7753 Only)

OUTPUT LEVEL: Programmable 50V to 500V (Ch. 28).

PROGRAMMING RESOLUTION: 100mV.

OUTPUT CURRENT: (7751) 50µA maximum for rated accuracy, <1mA typical into short circuit.
(7753) 500µA maximum for rated accuracy, <1mA typical into short circuit.

ACCURACY: ±(0.5% + 0.13V) (2 year specification).

SETTLING TIME: Rise Time: 50V to 500V step, 0.1% of final value, 250ms max.
Fall Time: 500V to 50V step, 0.1% of final value, 1000ms max.

TEMPERATURE COEFFICIENT (0–18°C & 28–40°C): ±(0.001% + 0.005V)/°C.

SAFETY LIMIT: Current limited maximum current of 1mA.

CABLE DISCHARGE (Ch. 20): 100kΩ shunt.

MAXIMUM CAPACITANCE: 1nF.

CURRENT MEASURE INPUT (7751/7753 Only)

RANGE: 7751: 0–50µA. 7753: 0–500µA.

ACCURACY: 7751: ±(0.5% of reading + 6nA) (2 year specification).

7753: ±(0.5% of reading + 60nA) (2 year specification).

TEMPERATURE COEFFICIENT (0–18°C & 28–40°C): ±(0.02%+0.5nA)/°C.

VOLTAGE BURDEN: <1mV.

SWITCHING CAPABILITIES (Bank 1–Bank 4)

4 CHANNELS: 1 Form A switch.

8 CHANNELS: Four 4-pole or eight 2-pole signals into DMM or I/V converter.

CONTACT CHECK: 4-wire contact check through internal DMM.

RELAY TYPE: Latching electromechanical.

ACTUATION TIME: <3ms.

CONTACT LIFE (typical): >10⁶ operations at maximum source level.
>10⁸ operations cold switching.

CONTACT RESISTANCE: <1Ω at end of contact life.

CONTACT POTENTIAL: <±2µV typical per contact pair, ±3µV max.

CONNECTOR TYPE: Plugable screw terminal, #22 AWG wire size.

ISOLATION BETWEEN ANY TWO TERMINALS¹: >1GΩ, <100pF.ISOLATION BETWEEN TERMINALS AND EARTH¹: >1GΩ, <200pF.ISOLATION BETWEEN CHANNEL GROUPS¹: >500GΩ, <100pF.

EXTERNAL COMMON MODE VOLTAGE: 42V between any terminal and chassis. (Connect no external sources.)

7751, 7752, OR 7753 MODULE NOTES

- 1 Isolation for channels 1–12, only one channel closed at a time, or all channels open.
- 2 See User's Manual for ohm specifications at sources other than those specified.
- 3 All specifications valid for 1 NPLC ADC aperture setting.

SYSTEM THROUGHPUT

(Connect, source, measure, calculate)

0.01 NPLC, FILTER OFF, OVER GPIB BUS: High Ohms (Source V): 13 rdgs/s!
Low Ohms (Source I): 9 rdgs/s.1 NPLC, FILTER ON, OVER GPIB BUS: High Ohms (Source V): 11 rdgs/s!
Low Ohms (Source I): 7 rdgs/s.

SYSTEM THROUGHPUT NOTES

- 1 Reset upon fixed V_{source} level, no settling time.

BASIC AIRBAG TEST SEQUENCE THROUGHPUT

(Body Pin + Bridgewire Continuity = Shorting Clip + Insulation Resistance)

0.55/0.97 seconds for single/dual stage DUT w/scan (sequential) memory patterns.

1.0/2.0 seconds for single/dual stage DUT w/recall (random access) memory patterns.

1.1/1.7 seconds for single/dual stage DUT discrete control w/GPIB I/O.

(Sequence times are totals @ 1 line cycle integration for rated accuracy)

1.888.KEITHLEY (U.S. only)

www.keithley.com

KEITHLEY

