

Rotating 4-Component Dynamometer RCD

for Cutting Force Measurement up to 5 000 1/min

Type 9124B..., 5221B2,
5223B...

Rotating 4-component dynamometer for measuring of cutting forces and torques on the rotating tool spindle. Transmission of measured data by telemetry hence without wear.

- Cutting force measurement on the rotating edge
- 4-component force/moment measurement
- Data transmission by telemetry
- Internal coolant supply
- Conforming to CE

Description

The dynamometer consists of a four component sensor fitted under high preload between a baseplate and a top plate.

The four components are measured practically without displacement.

It must be taken into account that combined and eccentric loads may reduce the measuring ranges.

The sensor is mounted ground-insulated. Therefore ground loop problems are largely eliminated.

The dynamometer is rustproof and protected against penetration of splashwater and cooling agents.

For each component a 2-range miniature charge amplifier is integrated in the dynamometer. The output voltages of the charge amplifiers are digitized and transmitted by telemetry to the stator. The remote controlled range switching and an optionally switchable zoom channel allow to use the measuring ranges in an optimal manner.

The voltage is supplied per induction.

A zero point identification (Type 5223B2) is available as an option which allows to correlate the force signals with the tool edge.

The dynamometer is delivered preferably with integrated spindle adapter (according to option). For mounting the cutting tools, tool adapter Type 9165 is available.

Application

Investigation of wear and cutting processes near the tool edge during milling and drilling. The acting force vector on one-edged tools can directly be measured. This dynamometer is especially suitable for rough-machining.

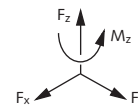

Technical Data

Dynamometer Type 9124B...

Speed		1/min	max. 5 000
Range 1 FSO	F _x , F _y	kN	-20 ... 20*
		kN	-15 ... 15**
	F _z	kN	-30 ... 30
	M _z	Nm	-1 100 ... 1 100
Range 2 FSO (switchable)	F _x , F _y	kN	-2 ... 2
	F _z	kN	-3 ... 3
	M _z	Nm	-110 ... 110
Overload range 1		%	20
Threshold	F _x , F _y	N	<4
	F _z	N	<6
	M _z	Nm	<0,3
Sensitivity (Range 1)	F _x , F _y	mV/N	≈0,5
	F _z	mV/N	≈0,33
	M _z	mV/Nm	≈9
Linearity		% FSO	≤±1
Hysteresis		% FSO	≤1
Crosstalk	F _x ↔ F _y	%	≤±2
	F _z → F _{x,y}	%	≤±3
	F _{x,y} → F _z	%	≤±3
	M _z → F _z	N/Nm	≤±3
Natural frequency Type 9124Bxx11 measured without telemetry	f _n	kHz	≈1

Operating temperature range		°C	0 ... 60
Degree of protection EN60529			IP67
Weight Type 9124B1111		kg	≈7,5

* Force application point at the top plate area

** Force application point 50 mm above top plate area

Stator and Multichannel Signal Conditioner

Type 5221B2 and Type 5223B...

Ratio range 1/range 2			10
Number of channels			5
Number of ranges per channel			2
Cut-off frequency per channel	f_{cutoff}	kHz	1,0
Sampling rate per channel		kHz	7,8
Resolution/tolerance		bit/%	12/±0,025
Signal output (FSO)		V	±10
Output connector (analog signal)			5 x BNC neg. 15 pin D-Sub

Operating temperature range	°C	0 ... 60
Power supply (switchable)	V/AC	230/115
	%	+15/-22
	Hz	48 ... 62
Power consumption	VA	≈30
Dimensions (DIN41494, part 5)		
Width	TE	63
Height of instrument	HE	4
Height of plug-in	HE	3
With case	mm	340x187x280
Weight Type 5223B...	kg	8
Interface for remote control		RS-232C
Zero point identification (only Type 5223B2)		
Signal output	V	+5
Output connector		BNC neg.

Zoom (window amplifier):

The zoom decouples the output signal of an optional channel and amplifies the signal by a factor 10.

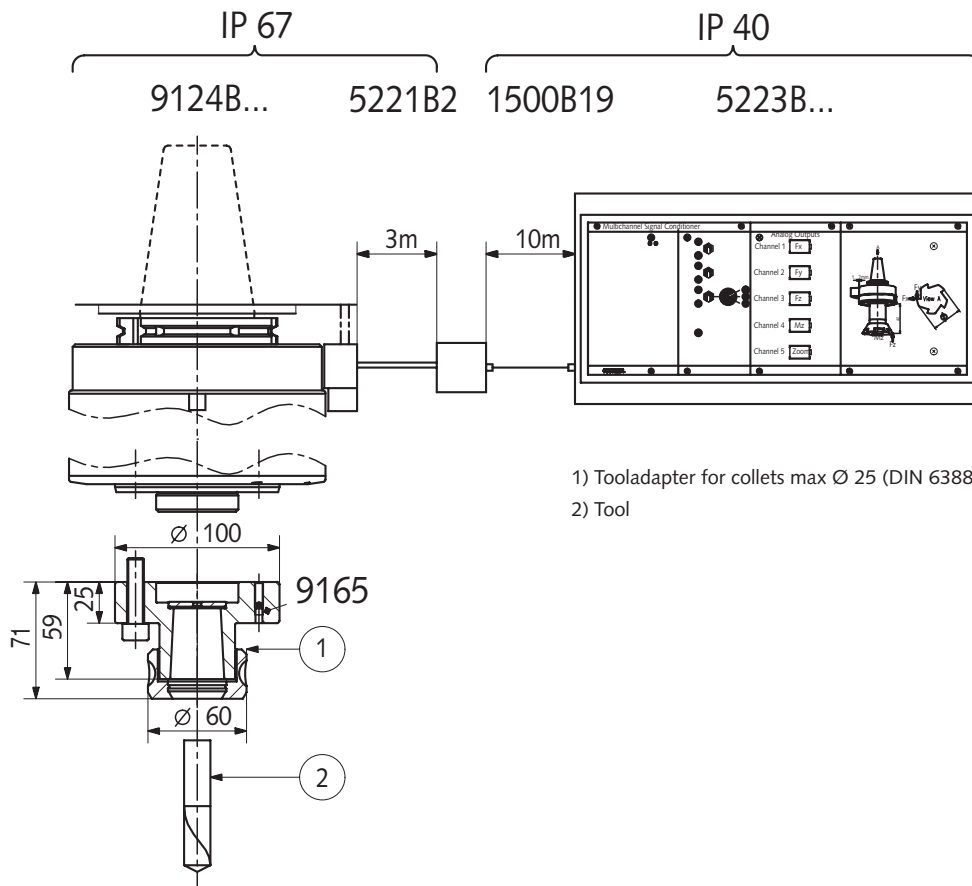

- 1) Tooladapter for collets max Ø 25 (DIN 6388)
- 2) Tool

Fig. 1: Rotating Cutting Force Measuring System

000-122e-01.04 (DB06.9124m)

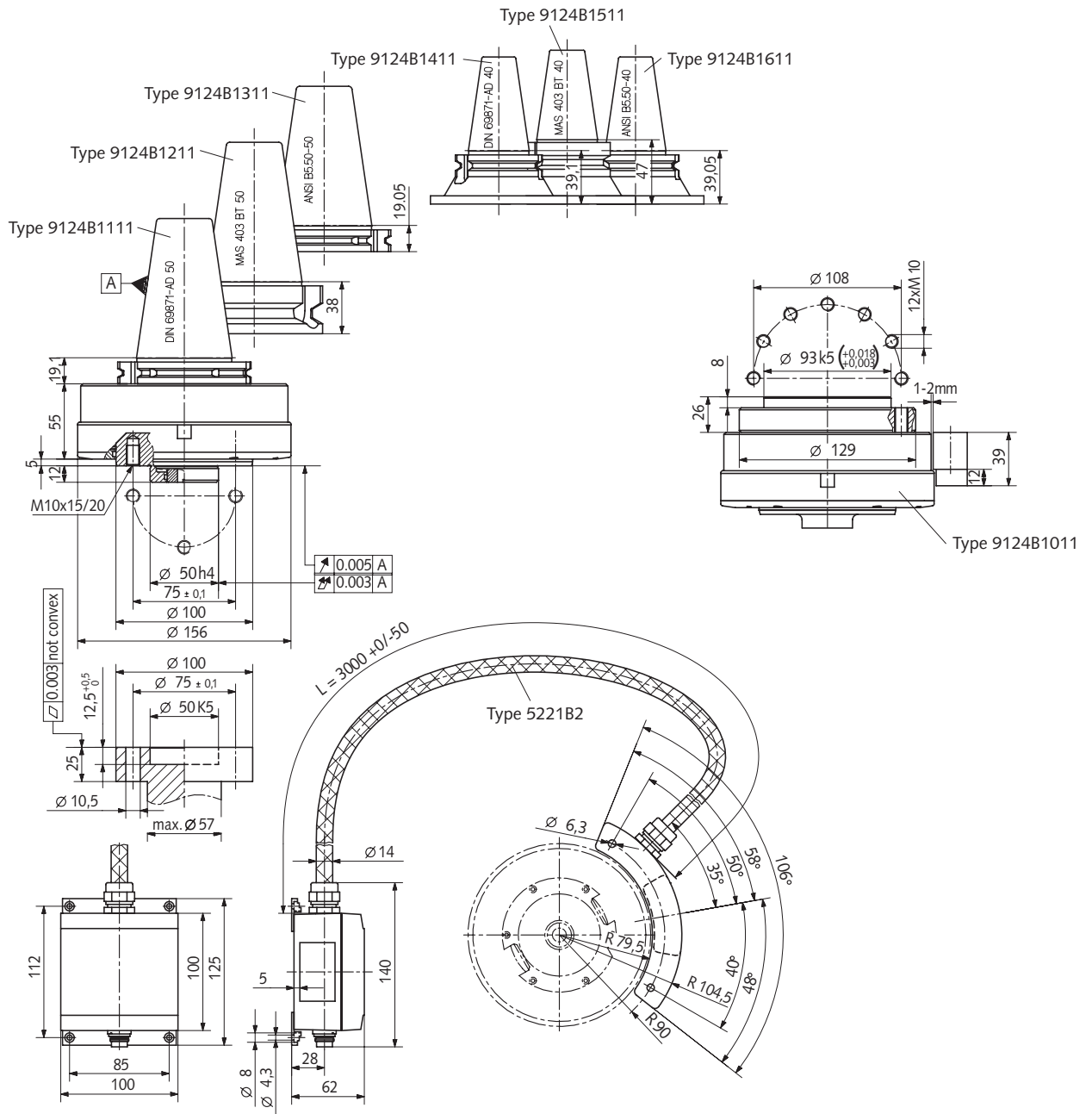

Fig. 2: Dimensions Dynamometer Type 9124B...

Optional Accessories

- Stator Type 5221B2
- Connecting cable 1500B19
- Multichannel signal conditioner 5223B1
- Multichannel signal conditioner with zero point identification 5223B2
- Tool holder 9165

Ordering Key

Spindle adapter*

without spindle adapter	10
DIN 69871-AD 50	11
MAS 403 BT 50	12
ANSI B5,50 - 50	13
DIN 69871-AD 40	14
MAS 403 BT 40	15
ANSI B5,50 -40	16

9124B 11

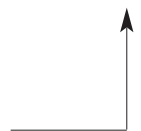

* other spindle adapters on request

000-122e-01.04 (DB06.9124m)