

# 3-Component Force Sensor

Diameter 40 mm up to 20 kN

Type 9047B, 9048B,  
9046B4

Quartz force sensor for measuring the three orthogonal components of a dynamic or quasistatic force acting in an arbitrary direction.

Very extended measuring range, high rigidity and minimal cross talk.

- Measures the 3 components of a force
- Compact, despite large measuring range
- Multipole connector

### Description

The force sensor contains 3 quartz rings which are mounted between two steel plates in the sensor housing.

Two quartz rings are sensitive to shear and measure the force components  $F_x$  and  $F_y$ , while one quartz plug is sensitive to pressure measures the component  $F_z$  of a force acting on the sensor. The electrical charges proportional to the different components are led via electrodes to the corresponding connectors.

The quartz packet is protected by the stainless, tightly welded sensor housing.

Two ceramic layers on both sides of the sensor guarantee ground insulation of the mounted sensor.

### Application

The quartz force sensors can measure the 3 orthogonal force components easily, directly and precisely, because these sensors feature an inherently low cross talk.

Thanks to their high rigidity they cover a wide frequency range.

### Application examples

- Cutting forces
- Impact forces
- Reaction forces in rockets
- Dynamic forces on shakers
- Determination of coefficients of friction

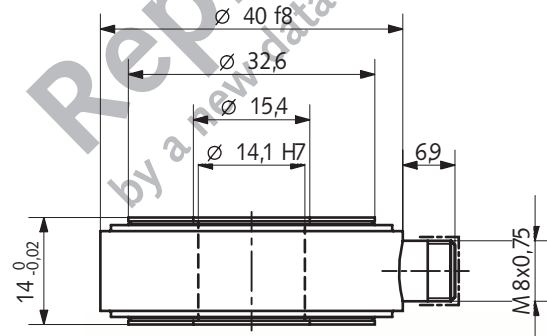

### Technical Data

Range	$F_x, F_y$	kN	-10 ... 10 <sup>1)</sup>
	$F_z$	kN	-20 ... 20 <sup>1)</sup>
	$F_z$	kN	0 ... 80 <sup>2)</sup>
Overload	$F_x, F_y$	kN	-12/12 <sup>1)</sup>
	$F_z$	kN	-24/24 <sup>1)</sup>
	$F_z$	kN	96 <sup>2)</sup>
Calibrated range	$F_x$	kN	0 ... 10 <sup>1)</sup>
	$F_y$	kN	0 ... 10 <sup>1)</sup>
	$F_z$	kN	0 ... 20 <sup>1)</sup>
	$F_z$	kN	0 ... 80 <sup>2)</sup>
Threshold		N	<0,01
Sensitivity	$F_x, F_y$	pC/N	≈8,1 <sup>1)</sup>
	$F_z$	pC/N	≈3,7 <sup>1)</sup>
Linearity, each axis		%FSO	≤±1 <sup>1)</sup>
Hysteresis, each axis		%FSO	≤0,5 <sup>1)</sup>
Crosstalk	$F_z \rightarrow F_x, F_y$	%	≤±1 <sup>1)</sup>
	$F_x \leftrightarrow F_y$	%	≤±2 <sup>1)</sup>
	$F_x, F_y \rightarrow F_z$	%	≤±4 <sup>1)3)</sup>
Rigidity	$c_x, c_y$	N/μm	≈600
	$c_z$	N/μm	≈1 400
Max. moments	$M_x, M_y$	N·m	-200/200 <sup>1)</sup>
	$M_z$	N·m	-120/120 <sup>1)</sup>

<sup>1)</sup> Standard mounting with preload of 60 kN

<sup>2)</sup> Without preload

<sup>3)</sup> Crosstalk  $F_x, F_y, F_z$  is ≤±2 % if e.g. four sensors are assembled into one dynamometer

**Other Technical Data**

Operating temperature range	°C	-50 ... 120
Insulation resistance	Ω	≥10 <sup>13</sup>
Ground insulation	Ω	>10 <sup>8</sup>
Capacitance, each channel	pF	≈50
Connector		3 pole M8x0,75
Weight	g	76

**Other Descriptions**

**Types 9047B and 9048B**

The sensors Types 9047B and 9048B differ only in the position of the coordinate system relative to the sensor case (see Fig. 1). The technical data of both types are identical.

**Type 9046B4**

**Sets consisting of four selected 3-Component Force Sensors**

These sets, Type 9046B4, consist of four selected three-component force sensors two of each Type 9047B and 9048B. Commonly ground to the same thickness, they are used for mounting into multicomponent dynamometers and force plates.

All connectors of the four sensors are oriented toward the inside, (see Fig.2).

The four force sensors are selected in a way to possess optimal specifications of constant sensitivity and minimal cross talk when they are mounted into a dynamometer.

This configuration permits a very compact mounting, e.g. in a dynamometer.

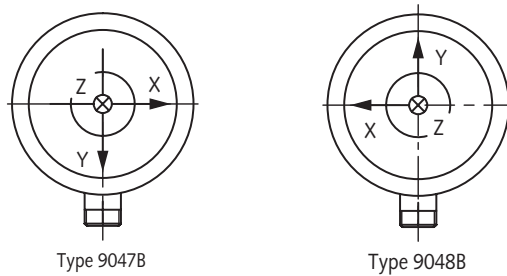

Fig. 1: 3-Component Force Sensor Type 9047B and 9048B

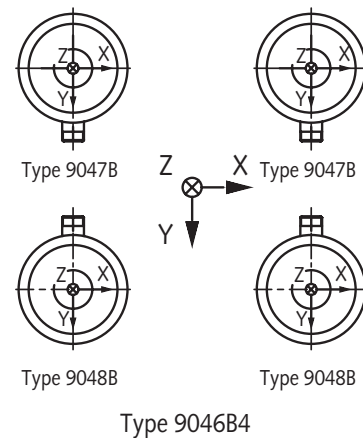

Fig. 2: Set consisting of 3-Component Force Sensors, two of each Type 9047B and 9048B

**Mounting**

The force sensor must be mounted under preload because the shear forces  $F_x$  and  $F_y$  are to be transmitted through static friction from the base and cover plate to the faces of the force sensor. The necessary preload depends on the shear forces to be transmitted.

The measuring ranges indicated in the technical data are valid for the standard preload of 60 kN.

The sensor is preloaded with a centered preloading bolt. The cable outlet serves to orient the sensor.

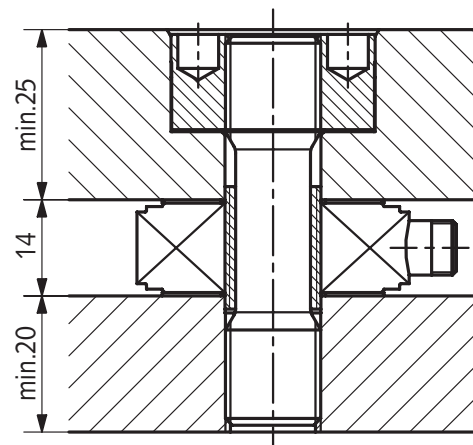

Fig. 3: Standard preloading with preloading set Type 9465...

This preloading method allows a very compact mounting of dynamometers. A minimum overall height is obtained by recessed mounting of the ring nut.

Further information see data sheet of Type 9465.

9047B\_000-116e-12.04

The force sensors types 9047B and 9048B are available already mounted and calibrated in the form of a force link see data sheet of Type 9347B.

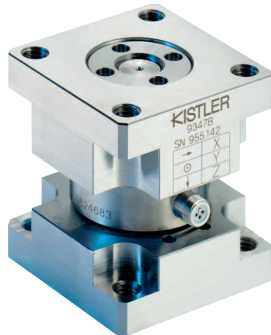

Fig. 4: Force Links Type 9347B/9348B

### Parallel Switching

Several quartz sensors of identical sensitivities can be paralleled directly. The charge amplifier connected then gives an output voltage which corresponds to the sum of all forces acting.

This is a great advantage when building force plates and dynamometers with which only the 3 components of the resulting force must be measured.

### Electronics

Besides the force sensors, a 3-component force measuring system also requires 3 charge amplifiers, which convert the electrical charge signals of the sensor into voltages exactly proportional to the three components  $F_x$ ,  $F_y$  and  $F_z$  of the acting force. In order to construct multicomponent dynamometers for measuring three forces and three moments, special multi-channel charge amplifiers are available.

### Systems for Multicomponent Measurements

Information concerning cable concept see supplement for data sheet of Types 9017/47/67/77.

### Accessories Included

The preloading elements are not included in the delivery; they must be ordered separately.. See data sheet of Type 9465.

### Optional Accessories

- |                    |           |
|--------------------|-----------|
| • Preloading set   | Type 9465 |
| • Wrench adapter   | 9472      |
| • Connecting cable | 1693A...  |
| • Connecting cable | 1694A...  |
| • Connecting cable | 1695A...  |

### Ordering Key

#### 3-Component Force Sensor

- 3-Component Force Sensor with standard coordinate system (see Fig. 1)

Type  
**9047B**

#### 3-Component Force Sensor

- 3-Component Force Sensor like Type 9047B, but with coordinate system rotated 180° about z-axis (see Fig. 1)

**9048B**

#### Set of 3-Component Force Sensors

- Set of four matched 3-Component Force Sensors ground together, two of each Type 9047B and 9048B (see Fig. 2)

**9046B4**