

Mold Cavity Pressure Sensor

HighSens with Front $\varnothing 6$ mm

Type 6172A...

Patent No. US 6,212,963

The quartz sensor for low pressure processes for injection molding of plastics with cavity pressures up to 200 bar.

- Ideally suited for industrial applications
- Sensor front can be machined to adapt to the cavity wall (except for coated versions of the sensor)
- Exchangeable cable

Description

The sensor Type 6172A... consists of the HighSens quartz sensor for mold cavity pressure Type 6177A... with exchangeable cable, fitted in a rugged adapter. The sensor Type 6177A... with 4 mm front diameter comes flush with the adapter front with an annular gap of $<10 \mu\text{m}$ and measures the pressure directly.

The pressure acts over the entire front of the sensor and is transmitted to the quartz measuring element, which produces a proportional electric charge ($\text{pC} = \text{Picocolomb}$). This is converted into a 0 ... 10 V output from a standard charge amplifier.

All parts of the sensor are corrosion resistant. The exchangeable cable is screwed to the sensor with a tight seal. The connector is self-locking and splash-proof.

For multi cavity applications the sensor Type 6172A is used without the single-wire connector Typ 1839. The Multi Cavity Set Type 6829A... and the Multi Sensor System Type 6831A... are described in the appropriate data sheets.

This sensor is available with several types of connecting cables (see page 2).

Application

This diaphragm-free sensor measures mold cavity pressures up to 200 bar during injection molding. It is particularly suitable for optimizing, monitoring and controlling the injection molding process of thermoplastics, elastomers, thermosets and SMC.

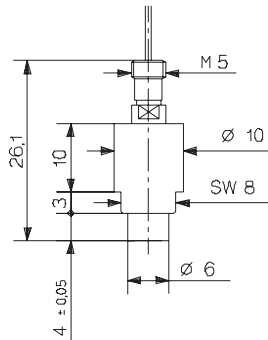

For abrasive melts (e.g. filled with glass fibers or carbon fibers, thermosets, BMC/SMC), these sensors are available as Types 6172AC.../AD... with a coated front.

With low viscosity melts (e.g. thermosets, SMC/BMC, IC sheaths), the silicone-filled Types 6172AAA.../ACA... must be used.

Technical Data

Range	bar	0 ... 200
Overload	bar	300
Sensitivity	pC/bar	-45
Linearity, all ranges	% FSO	$\leq \pm 1$
Operating temperature range		
Mold (Sensor, Cable)	$^{\circ}\text{C}$	0 ... 200
Melt (at front of sensor)	$^{\circ}\text{C}$	< 450
Connector	$^{\circ}\text{C}$	0 ... 200*
Insulation resistance		
at 20 $^{\circ}\text{C}$	T Ω	> 100
at 300 $^{\circ}\text{C}$	T Ω	$> 0,01$

* During machine down time, the mold temperature may rise to 240 $^{\circ}\text{C}$ without damaging the sensor; however, this may lead to measuring errors

6172A_000-512e-02.07

Pressure Sensor Type 6172AA.../AC...

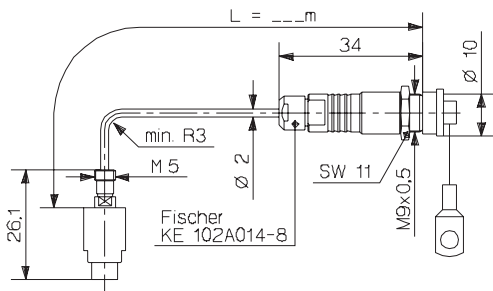

Installation

The sensor is normally installed in the mounting bore with the mounting nut Type 6453, but a spacer sleeve Type 6459 can also be used.

The sensor front forms part of the cavity wall. The sensor must therefore be shaped so that its front comes exactly flush and leaves no impression on the molded part. The front can be further machined up to 0,5 mm (except with a coated front!). Full details may be found in the operating instructions.

The sensor is center aligned in the 6 H7 bore.

Sensor with coaxial cable for temperatures up to 200 °C.

Pressure Sensor Type 6172A...E

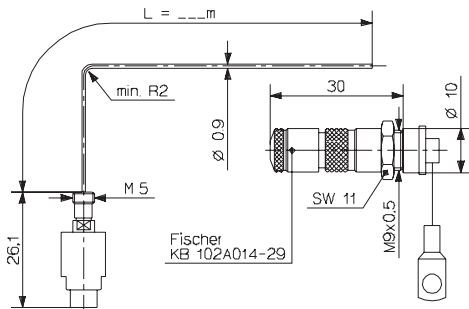

Sensor using single-wire technique for easy installation. The sensor Type 6172A...E is provided with a single-wire cable with a very small cross-sectional area and can be installed flexibly in the injection mold. The single-wire cable is exchangeable and can be cut to length as required. With the single-wire technique, electrical shielding is provided by the mold. It is therefore essential for the cable and connector to be completely integrated in the mold. To ensure easy installation, a connector is included which is self-locking and splash-proof.

Special Versions

Coated front (abrasion protection)

- Type 6172A... with coated front: Type 6172AC...

Silicone-filled gap

- Type 6172AA... gap filled with silicone: Type 6172AAA...

6172A_000-512e-02.07

Cable and Amplifier for Measuring Chain with Sensor Type 6172A...

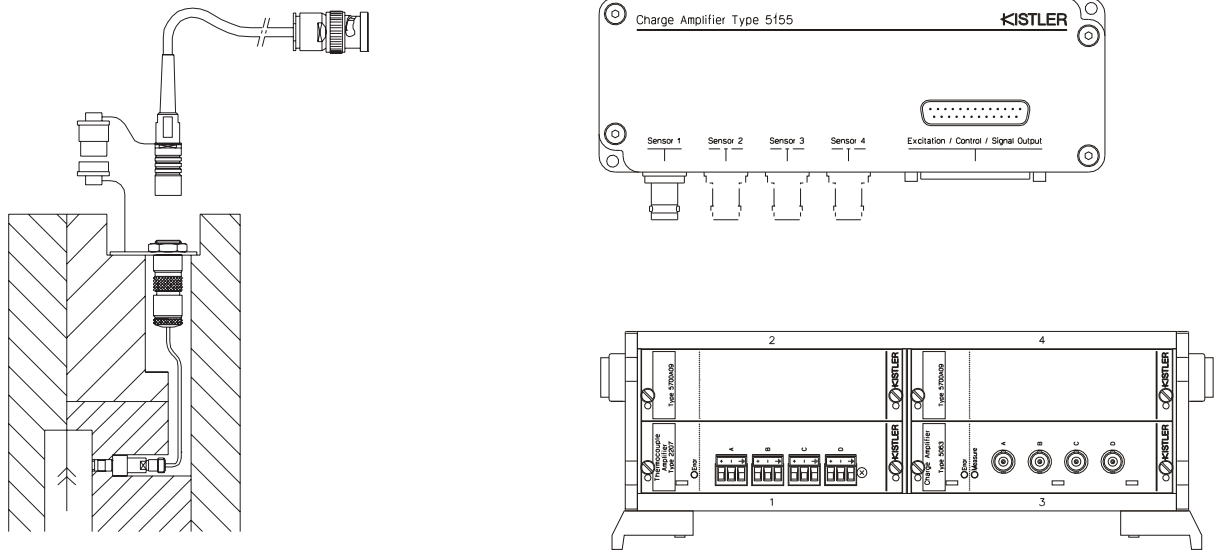

Cable Type 1667B... (BNC Connector)	Cable Type 1672B... (TNC Connector)
Type 5039Axx2	Type 5039Axx1
Type 5049Axx2	Type 5049Axx1
Type 5155Axx2x/Axx4x/Axx8x	Type 5155Axx1x/Axx3x/Axx7x
Type 5063A1 in Type 2859A.../2865A...	

Fig. 1: Sensor Type 6172A... with Charge Amplifier Type 5155A... or Signal Conditioner Type 2859/2865A...

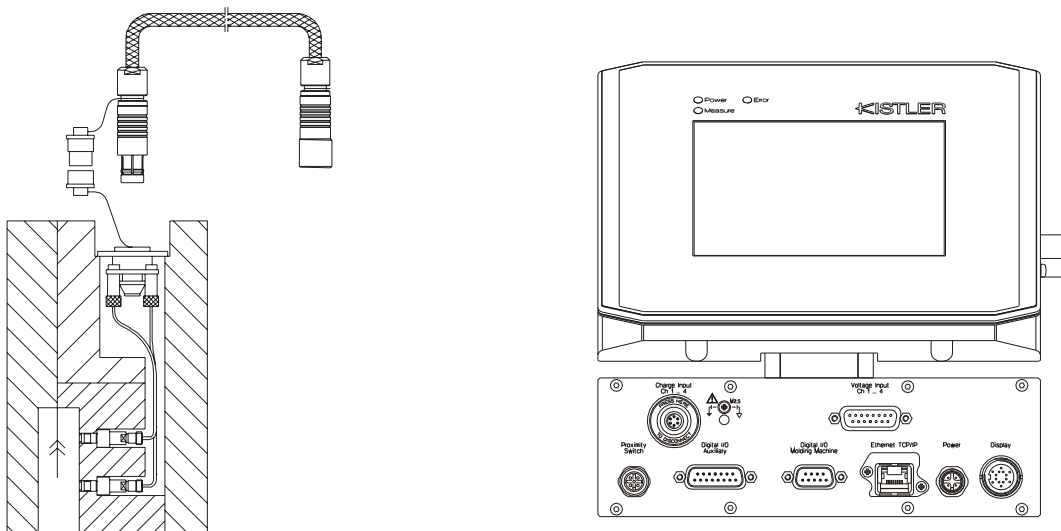

4-Channel Cable Type 1995A... to Connector Type 1708A..	8-Channel Cable Type 1997A... on Connector Type 1710A...
Type 2869A0xx	Type 2869A2xx
Type 2869A1xx	

Fig. 2: Sensor Type 6172A... with Monitoring System CoMo® Injection Type 2869A...

6172A_000-512e-02.07

Installation Examples

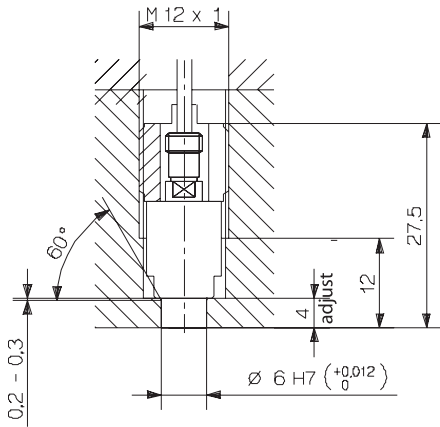

Fig. 3: Installation with mounting nut Type 6453

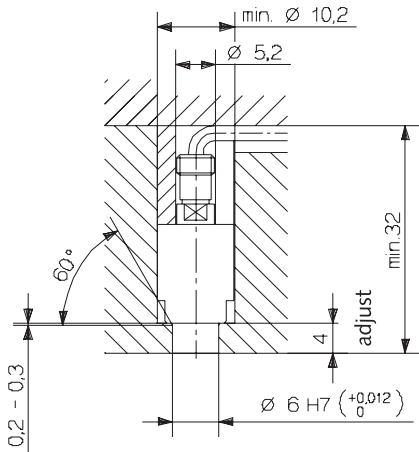

Fig. 4: Installation with spacer sleeve Type 6462

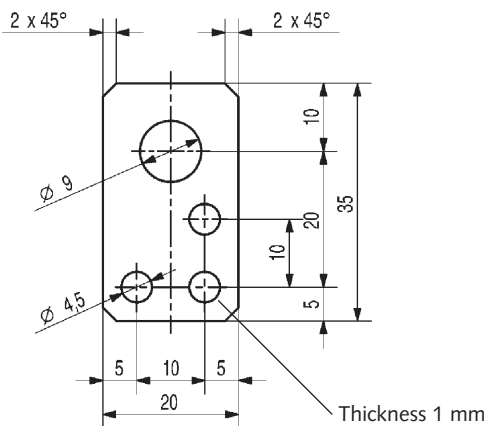

Fig. 5: Mounting plate (Art. No. 3.520.328)

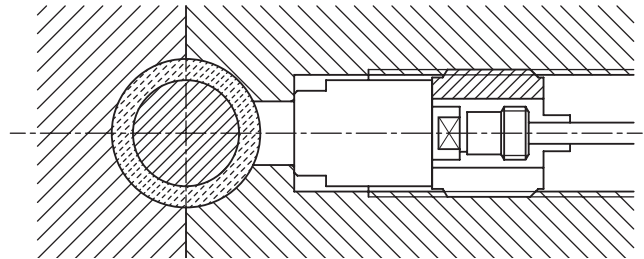

Fig. 6: Sensor with machined front Type 6172AA... only

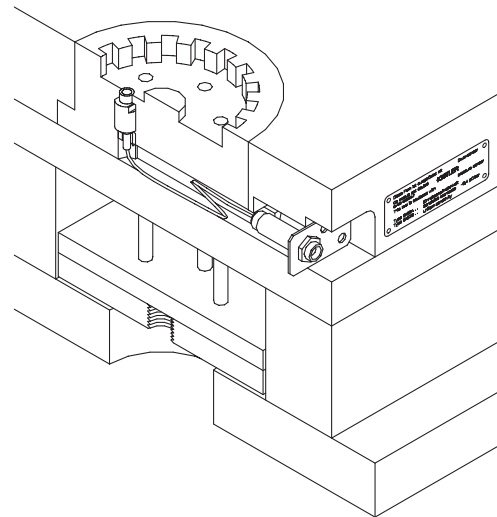

Fig. 7: Sensor, cable, connector, mounting plate (Art. No. 3.520.328) and identification label (Art. No. 3.520.899)

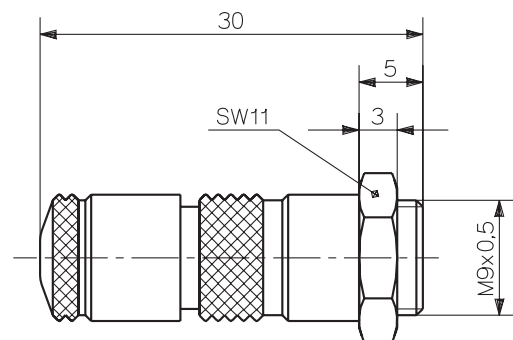

Fig. 8: Single-wire Fischer connector Type 1839

6172A_000-512e-02.07

Included Accessories

• Mounting nut	Art. No./Type 6453
• Mounting plate (for sensor with cable only)	3.520.328
• Identification label	3.520.899
• Connector (for single-wire technique only)	1839

Optional Accessories

• High temperature Viton® extension cable Fischer SE102A014 – BNC pos., Length 2 m	Type 1667B2
Length 5 m	1667B5
• High temperature Viton extension cable Fischer SE102A014 – TNC pos., Length 2 m	1672B2
Length 5 m	1672B5
• Spacer sleeve	6462
• Single-wire cable, with the length of 1,5 m (green)	1666A2
• Single-wire cable, with the length of 5 m (green)	1666A4
• Coaxial cable (green)	1645C...
• Dummy sensor	6552

• 4-channel connector for Type 6172A...G and 6172A...G1	1708A...
• 8-channel connector for Type 6172A...G and 6172A...G1	1710A...

Mounting Accessories

• Socket wrench	Type 1383
• Extraction tool	1315A
• Spanner to remove adapter	1352
• Tap M12x1	1355
• Mounting piece for connector	1401

Viton® is a registered trademark of DuPont Performance Elastomers

Ordering Key

Sensor

Cable up to 200 °C	A
Cable up to 200 °C, sensor front coated	C
Gap between sensor adapter filled with Silicone	A

Cable

Coaxial cable L in m	0,2
	0,4
	0,6
	0,8
Coaxial cable with special lengths, specify L in m (L _{min} = 0,1 m / L _{max} = 5 m)	sp
With single-wire cable (L = 1,5 m)	E
With single-wire cable (L = 5 m)	E1
Sensor 6172A...E (L = 1,5 m)	G
Sensor 6172A...E1 (L = 5 m)	G1

