

# WEATHERPROOF ABSORBER

## HYFRAL AI

HYFRAL AI are a range of pyramidal absorbers made of carbon loaded polyurethane foam, sealed in plastic coating to guarantee the waterproofness of the material.

### FIELD OF APPLICATION

HYFRAL AI absorbers are designed for outdoor uses (covering of metallic areas, reduction of radar cross section ...)

### INSTALLATION

HYFRAL AI absorbers can be fitted with either non metallic eyelet placed into the waterproof material or using adhesives.

### MAIN CHARACTERISTICS

**Matrix:**

90 % open cell. Polyurethane foam

**Standard sizes:**

610 X 1220 mm (other sizes available on request)

**Impregnating agents:**

carbon, binder, fire retardant.

**Colours:**

grey (other colours available upon request).

**Max. service temp.:**

[-70 ; +50]°C

**Power handling:**

0.13 W/cm<sup>2</sup> max continuous.

**Plastic coating fire resistance:**

M2 (upon request).

Perspective view

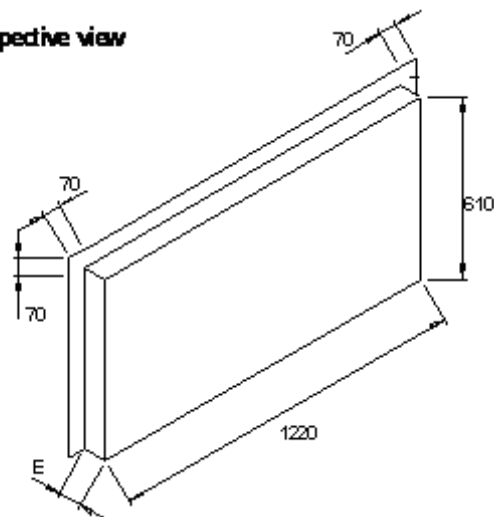

MINIMUM REFLECTIVITY OF HYFRAL AI in dB for incidence angles close to the normal

Type	E (mm)	200 MHz	300 MHz	500 MHz	1 GHz	2 GHz	4 to 18 GHz
AI 5	95					-15	-20
AI 9	130				-14	-21	-27
AI 12	155				-18	-28	-30
AI 20	250			-15	-28	-30	-30
AI 30	345			-22	-30	-30	-30
AI 45	495			-28	-30	-30	-30
AI 55	590		-20	-30	-30	-30	-30
AI 66	700	-15	-25	-30	-30	-30	-30

These data are the result of tests performed in our laboratory. They are considered to be the best of our knowledge. The use of the material and the specification of the performances are made under the whole responsibility of users who should ensure themselves that the material is suitable for their purposes.